

1 BEDROOM



TYPE A1

41 sqm / 441 sqft
(128) #01-01, #02-01, #03-01, #04-01, #05-01

Schematic Diagram

Block 128 Sophia Road Singapore 228184		Unit	1	2	3	4	5	6	7	8
5		A1	DK2b	C3b	A2b	A3	C1b	D1	C8	
4		A1	DK2b	C3b	A2b	A3	C1b	D1	C8	
3		A1	DK2b	C3b	A2b	A3	C1b	D1	C8	
2		A1	DK2b	C3b	A2b	A3	C1b		C8	
1		A1(p)	DK2a	C3a	A2a	A3(p)	C1a		C8(p)	

Block 130 Sophia Road Singapore 228185		Unit	9	10	11	12	13	14	15	16
5		B1b	C5b	C9b	C4	B2	C7b	C6b	C2b	
4		B1b	C5b	C9b	C4	B2	C7b	C6b	C2b	
3		B1b	C5b	C9b	C4	B2	C7b	C6b	C2b	
2		B1b	C5b	C9b	C4	B2	C7b	C6b	C2b	
1		B1a	C5a	C9a	C4(p)	B2(p)	C7a	C6a	C2a	

					
1 BEDROOM	2 BEDROOM DELUXE	2 BEDROOM PREMIUM	2 BEDROOM PRESTIGE	3 BEDROOM	3 BEDROOM DUAL KEY

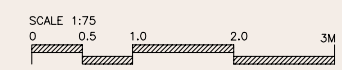
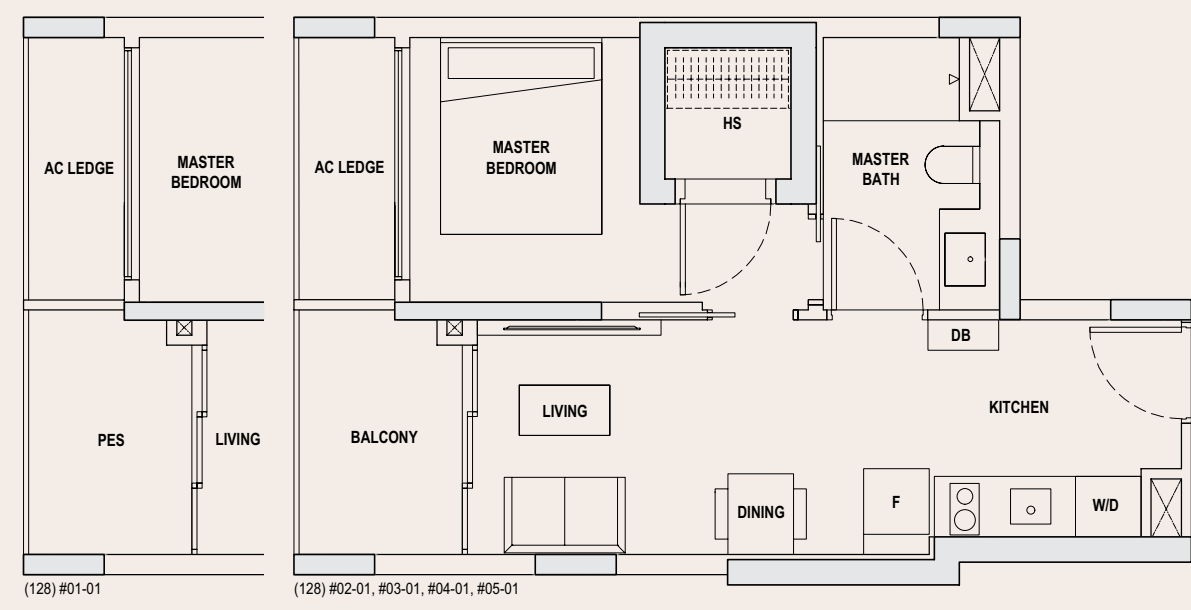

LEGEND

 W/D UNDER-COUNTER WASHER CUM DRYER	 F FRIDGE	 DB DISTRIBUTION BOX	 VOID SPACE
--	--	---	--

NOTE:
FOR INFORMATION OF VARYING LENGTH OF DIVIDING WALL BETWEEN ADJACENT UNITS AND/OR FACADE FEATURES VISIBLE TO UNITS, WHERE APPLICABLE, AND NOT DEPICTED IN THE UNIT FLOOR PLAN, PLEASE REFER TO THE RESPECTIVE BLOCK PLAN(S).

AREA INCLUDES A/C LEDGE, BALCONY AND JULIET BALCONY WHERE APPLICABLE. THE ABOVE PLANS AND ILLUSTRATIONS ARE SUBJECT TO CHANGE AS MAY BE REQUIRED OR APPROVED BY THE RELEVANT AUTHORITIES. ALL FLOOR AREAS ARE APPROXIMATE ONLY AND SUBJECT TO FINAL SURVEY. PLEASE REFER TO KEY PLAN FOR ORIENTATION.

BP No.: A2788-03660-2020-BP01 dated 05-06-2023

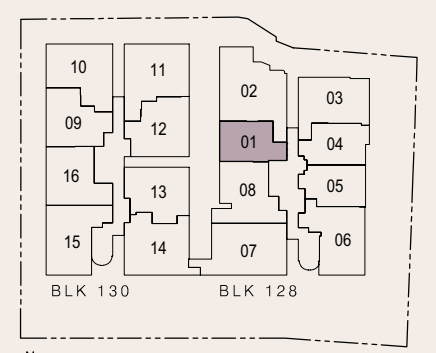

KEY PLAN
NOT DRAWN TO SCALE

TYPE A2a

1 BEDROOM

45 sqm / 484 sqft
(128) #01-04

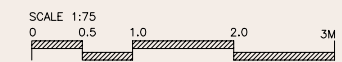
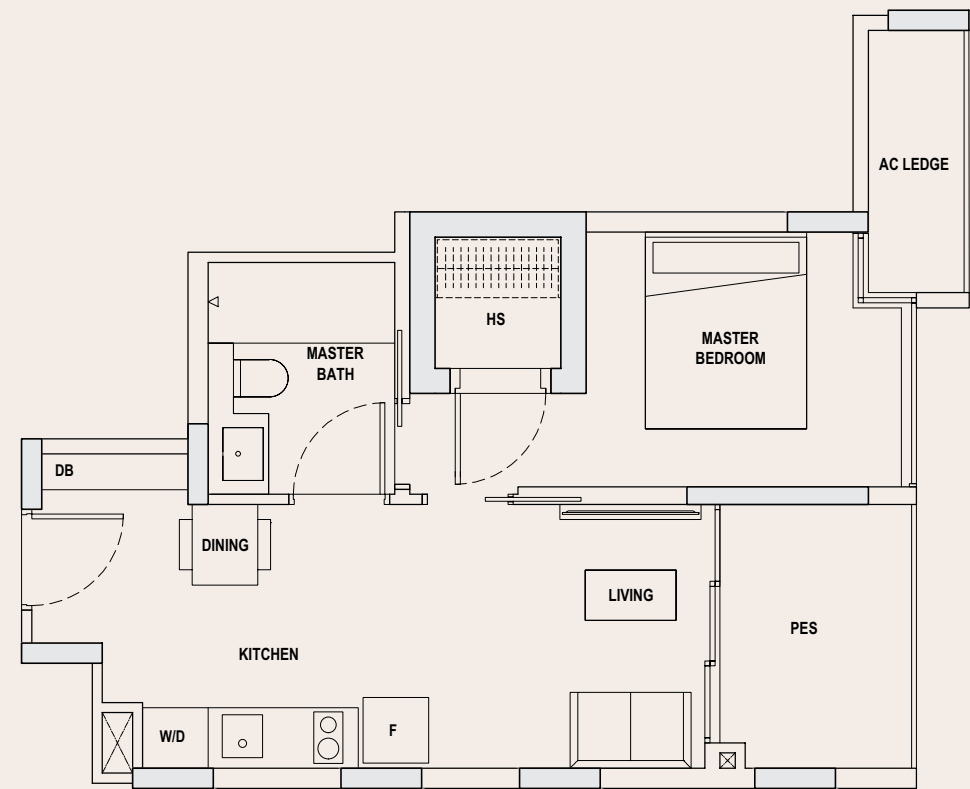

LEGEND

- W/D UNDER-COUNTER WASHER CUM DRYER
- F FRIDGE
- DB DISTRIBUTION BOX
- X VOID SPACE

NOTE:
FOR INFORMATION OF VARYING LENGTH OF DIVIDING WALL BETWEEN ADJACENT UNITS AND/OR FACADE FEATURES VISIBLE TO UNITS, WHERE APPLICABLE, AND NOT DEPICTED IN THE UNIT FLOOR PLAN, PLEASE REFER TO THE RESPECTIVE BLOCK PLAN(S).

AREA INCLUDES A/C LEDGE, BALCONY AND JULIET BALCONY WHERE APPLICABLE. THE ABOVE PLANS AND ILLUSTRATIONS ARE SUBJECT TO CHANGE AS MAY BE REQUIRED OR APPROVED BY THE RELEVANT AUTHORITIES. ALL FLOOR AREAS ARE APPROXIMATE ONLY AND SUBJECT TO FINAL SURVEY. PLEASE REFER TO KEY PLAN FOR ORIENTATION.

BP No.: A2788-03660-2020-BP01 dated 05-06-2023

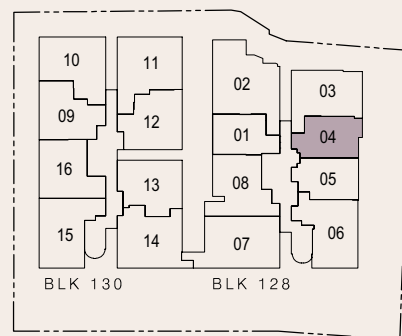

KEY PLAN
NOT DRAWN TO SCALE

1 BEDROOM

TYPE A2b

44 sqm / 474 sqft
(128) #02-04, #03-04, #04-04, #05-04

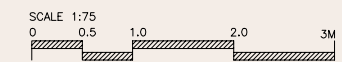
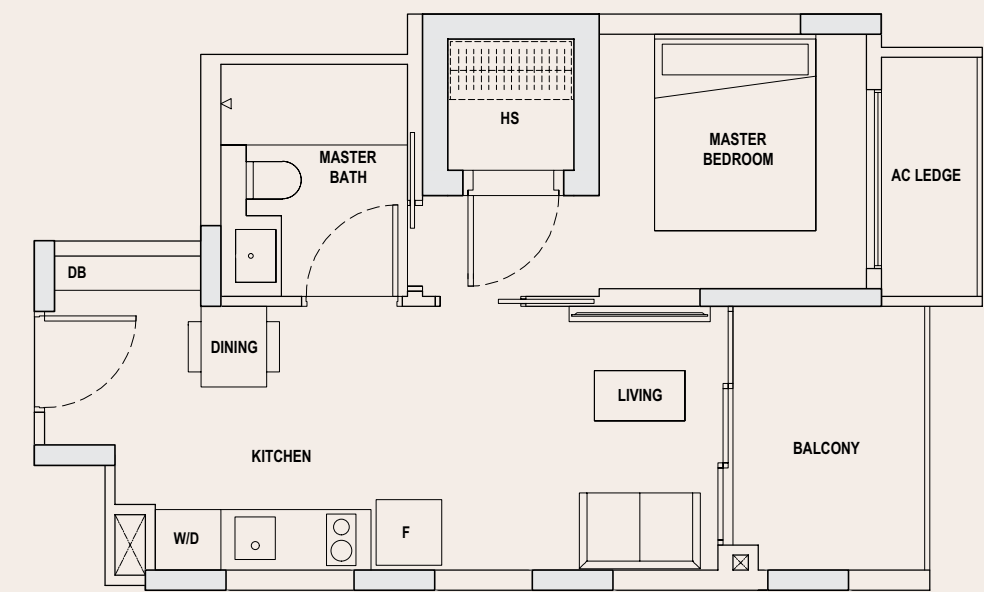

LEGEND

- W/D UNDER-COUNTER WASHER CUM DRYER
- F FRIDGE
- DB DISTRIBUTION BOX
- X VOID SPACE

NOTE:
FOR INFORMATION OF VARYING LENGTH OF DIVIDING WALL BETWEEN ADJACENT UNITS AND/OR FACADE FEATURES VISIBLE TO UNITS, WHERE APPLICABLE, AND NOT DEPICTED IN THE UNIT FLOOR PLAN, PLEASE REFER TO THE RESPECTIVE BLOCK PLAN(S).

AREA INCLUDES A/C LEDGE, BALCONY AND JULIET BALCONY WHERE APPLICABLE. THE ABOVE PLANS AND ILLUSTRATIONS ARE SUBJECT TO CHANGE AS MAY BE REQUIRED OR APPROVED BY THE RELEVANT AUTHORITIES. ALL FLOOR AREAS ARE APPROXIMATE ONLY AND SUBJECT TO FINAL SURVEY. PLEASE REFER TO KEY PLAN FOR ORIENTATION.

BP No.: A2788-03660-2020-BP01 dated 05-06-2023

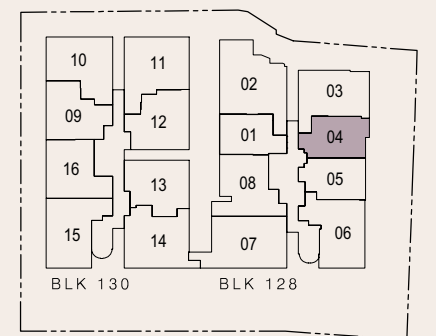

KEY PLAN
NOT DRAWN TO SCALE

TYPE A3

1 BEDROOM

43 sqm / 463 sqft
 (128) #01-05, #02-05, #03-05, #04-05, #05-05

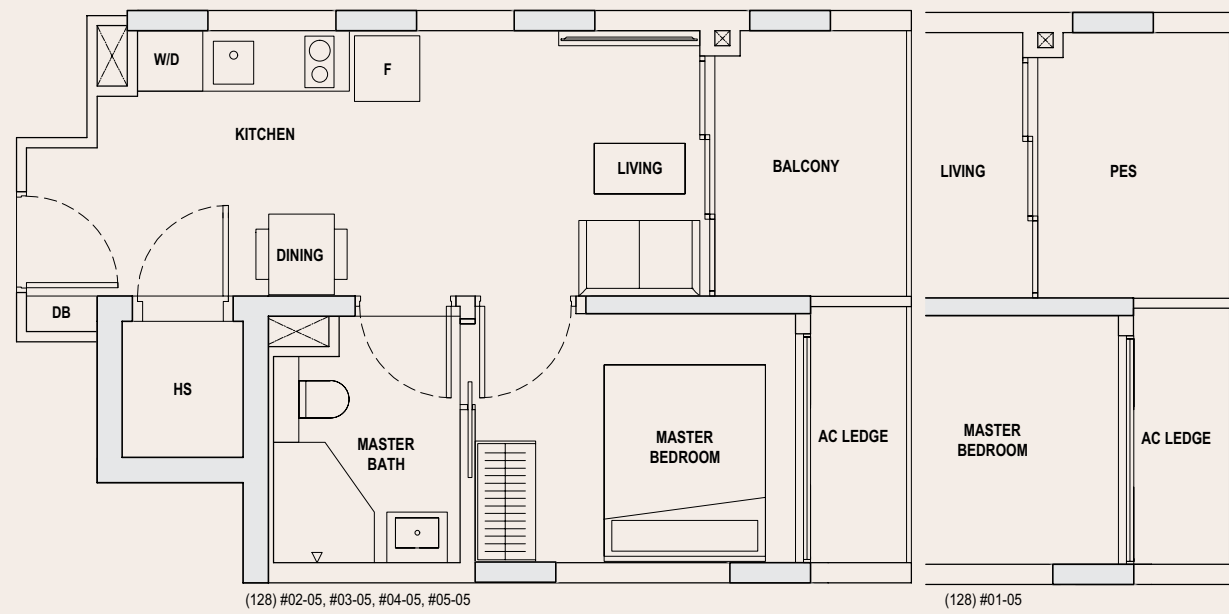

2 BEDROOM DELUXE

TYPE B1a

54 sqm / 581 sqft
 (130) #01-09

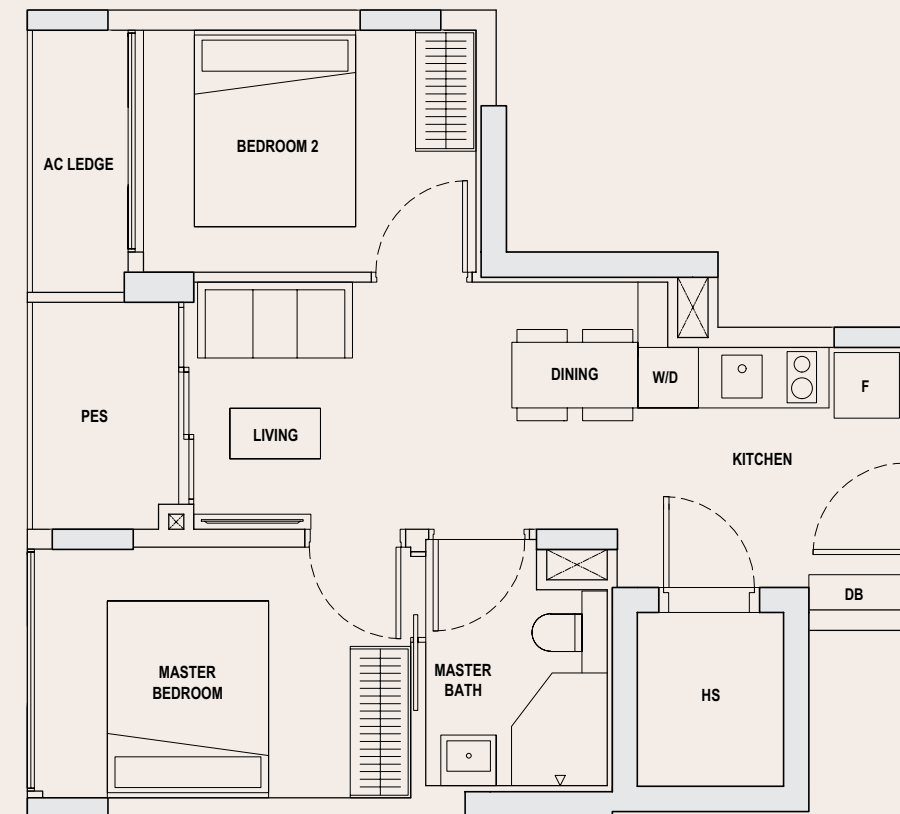

LEGEND

- W/D UNDER-COUNTER WASHER CUM DRYER
- F FRIDGE
- DB DISTRIBUTION BOX
- X VOID SPACE

NOTE:
 FOR INFORMATION OF VARYING LENGTH OF DIVIDING WALL BETWEEN ADJACENT UNITS AND/OR FACADE FEATURES VISIBLE TO UNITS, WHERE APPLICABLE, AND NOT DEPICTED IN THE UNIT FLOOR PLAN, PLEASE REFER TO THE RESPECTIVE BLOCK PLAN(S).

AREA INCLUDES A/C LEDGE, BALCONY AND JULIET BALCONY WHERE APPLICABLE. THE ABOVE PLANS AND ILLUSTRATIONS ARE SUBJECT TO CHANGE AS MAY BE REQUIRED OR APPROVED BY THE RELEVANT AUTHORITIES. ALL FLOOR AREAS ARE APPROXIMATE ONLY AND SUBJECT TO FINAL SURVEY. PLEASE REFER TO KEY PLAN FOR ORIENTATION.

BP No.: A2788-03660-2020-BP01 dated 05-06-2023

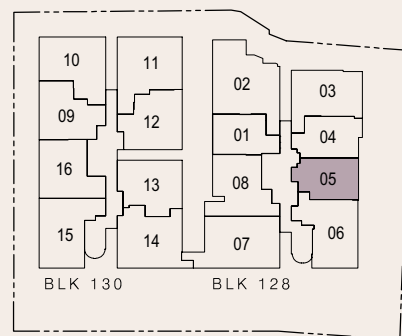

KEY PLAN
 NOT DRAWN TO SCALE

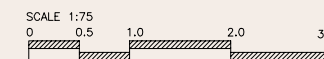

LEGEND

- W/D UNDER-COUNTER WASHER CUM DRYER
- F FRIDGE
- DB DISTRIBUTION BOX
- X VOID SPACE

NOTE:
 FOR INFORMATION OF VARYING LENGTH OF DIVIDING WALL BETWEEN ADJACENT UNITS AND/OR FACADE FEATURES VISIBLE TO UNITS, WHERE APPLICABLE, AND NOT DEPICTED IN THE UNIT FLOOR PLAN, PLEASE REFER TO THE RESPECTIVE BLOCK PLAN(S).

AREA INCLUDES A/C LEDGE, BALCONY AND JULIET BALCONY WHERE APPLICABLE. THE ABOVE PLANS AND ILLUSTRATIONS ARE SUBJECT TO CHANGE AS MAY BE REQUIRED OR APPROVED BY THE RELEVANT AUTHORITIES. ALL FLOOR AREAS ARE APPROXIMATE ONLY AND SUBJECT TO FINAL SURVEY. PLEASE REFER TO KEY PLAN FOR ORIENTATION.

BP No.: A2788-03660-2020-BP01 dated 05-06-2023

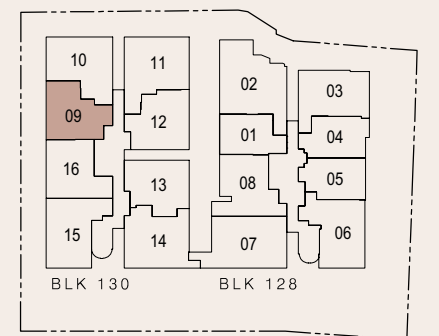

KEY PLAN
 NOT DRAWN TO SCALE

TYPE B1b

2 BEDROOM DELUXE

54 sqm / 581 sqft
 (130) #02-09, #03-09, #04-09, #05-09

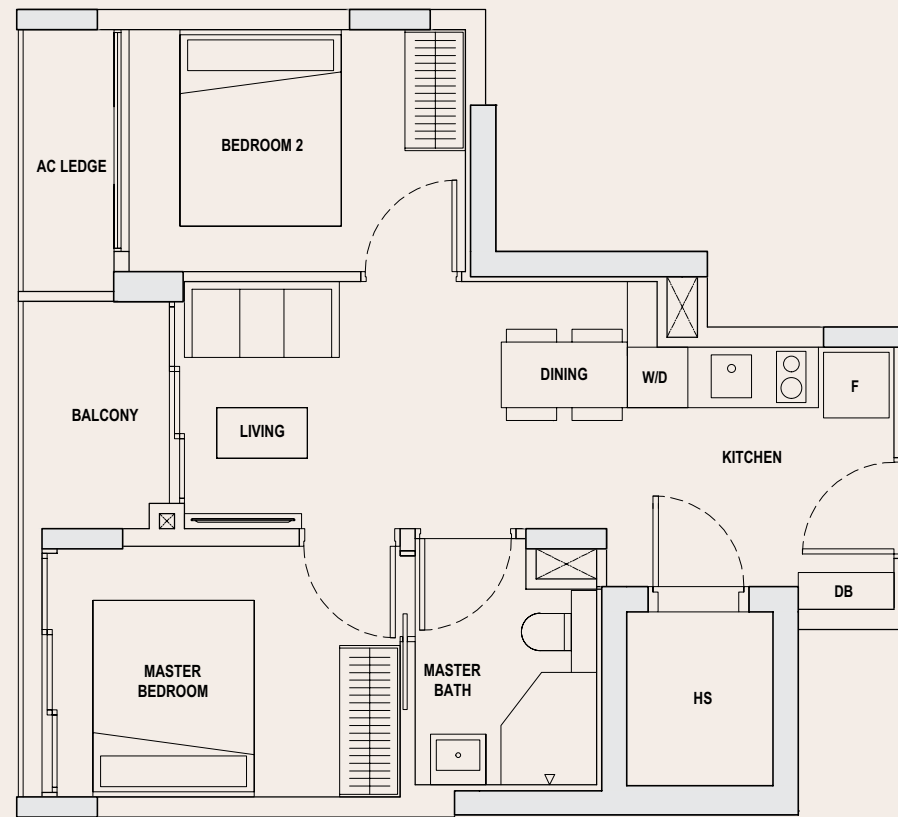

2 BEDROOM DELUXE

TYPE B2

54 sqm / 581 sqft
 (130) #01-13, #02-13, #03-13, #04-13, #05-13

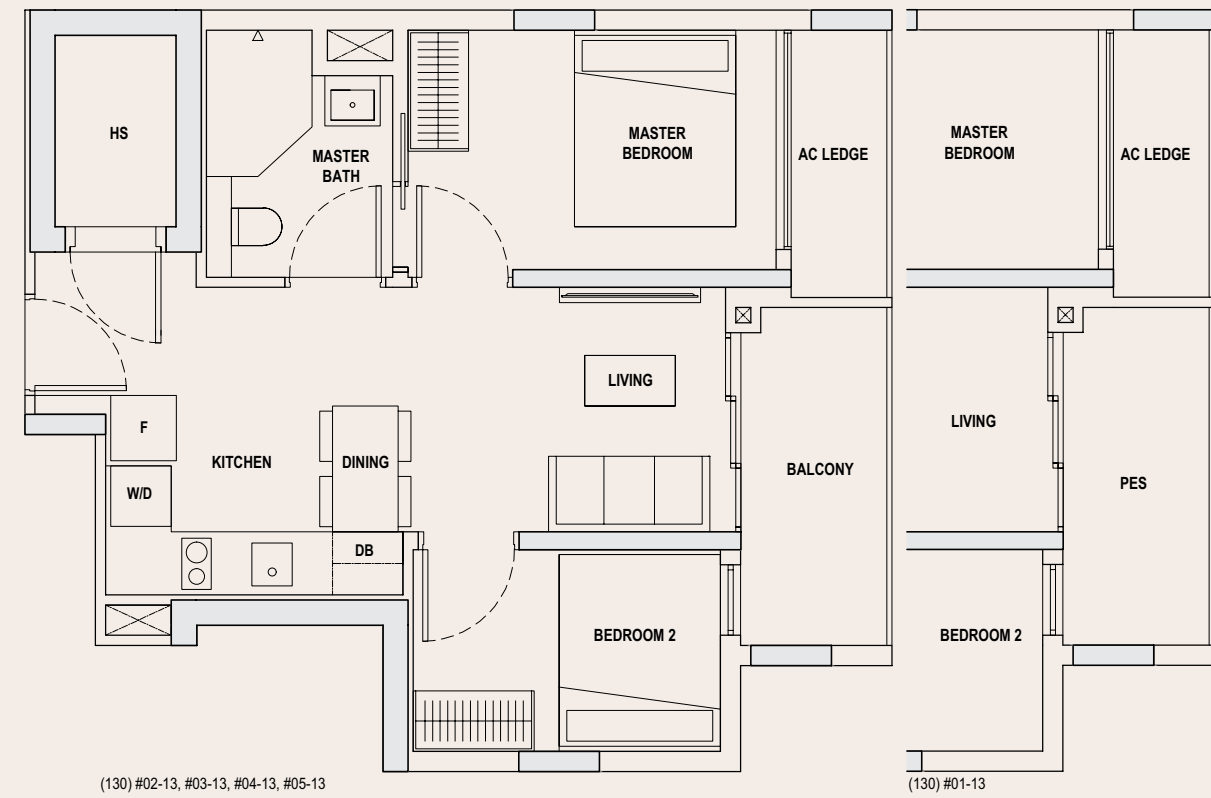

LEGEND

- W/D UNDER-COUNTER WASHER CUM DRYER
- F FRIDGE
- DB DISTRIBUTION BOX
- X VOID SPACE

NOTE:
 FOR INFORMATION OF VARYING LENGTH OF DIVIDING WALL BETWEEN ADJACENT UNITS AND/OR FACADE FEATURES VISIBLE TO UNITS, WHERE APPLICABLE, AND NOT DEPICTED IN THE UNIT FLOOR PLAN, PLEASE REFER TO THE RESPECTIVE BLOCK PLAN(S).

AREA INCLUDES A/C LEDGE, BALCONY AND JULIET BALCONY WHERE APPLICABLE. THE ABOVE PLANS AND ILLUSTRATIONS ARE SUBJECT TO CHANGE AS MAY BE REQUIRED OR APPROVED BY THE RELEVANT AUTHORITIES. ALL FLOOR AREAS ARE APPROXIMATE ONLY AND SUBJECT TO FINAL SURVEY. PLEASE REFER TO KEY PLAN FOR ORIENTATION.

BP No.: A2788-03660-2020-BP01 dated 05-06-2023

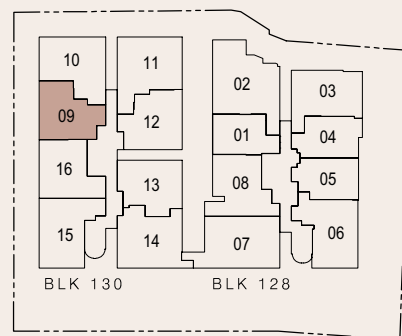

KEY PLAN
 NOT DRAWN TO SCALE

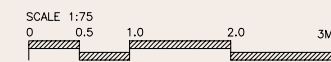

LEGEND

- W/D UNDER-COUNTER WASHER CUM DRYER
- F FRIDGE
- DB DISTRIBUTION BOX
- X VOID SPACE

NOTE:
 FOR INFORMATION OF VARYING LENGTH OF DIVIDING WALL BETWEEN ADJACENT UNITS AND/OR FACADE FEATURES VISIBLE TO UNITS, WHERE APPLICABLE, AND NOT DEPICTED IN THE UNIT FLOOR PLAN, PLEASE REFER TO THE RESPECTIVE BLOCK PLAN(S).

AREA INCLUDES A/C LEDGE, BALCONY AND JULIET BALCONY WHERE APPLICABLE. THE ABOVE PLANS AND ILLUSTRATIONS ARE SUBJECT TO CHANGE AS MAY BE REQUIRED OR APPROVED BY THE RELEVANT AUTHORITIES. ALL FLOOR AREAS ARE APPROXIMATE ONLY AND SUBJECT TO FINAL SURVEY. PLEASE REFER TO KEY PLAN FOR ORIENTATION.

BP No.: A2788-03660-2020-BP01 dated 05-06-2023

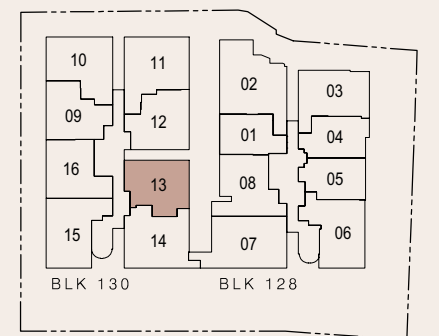

KEY PLAN
 NOT DRAWN TO SCALE

TYPE C1a

2 BEDROOM PREMIUM

52 sqm / 560 sqft
(128) #01-06

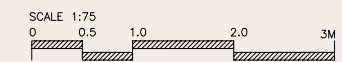
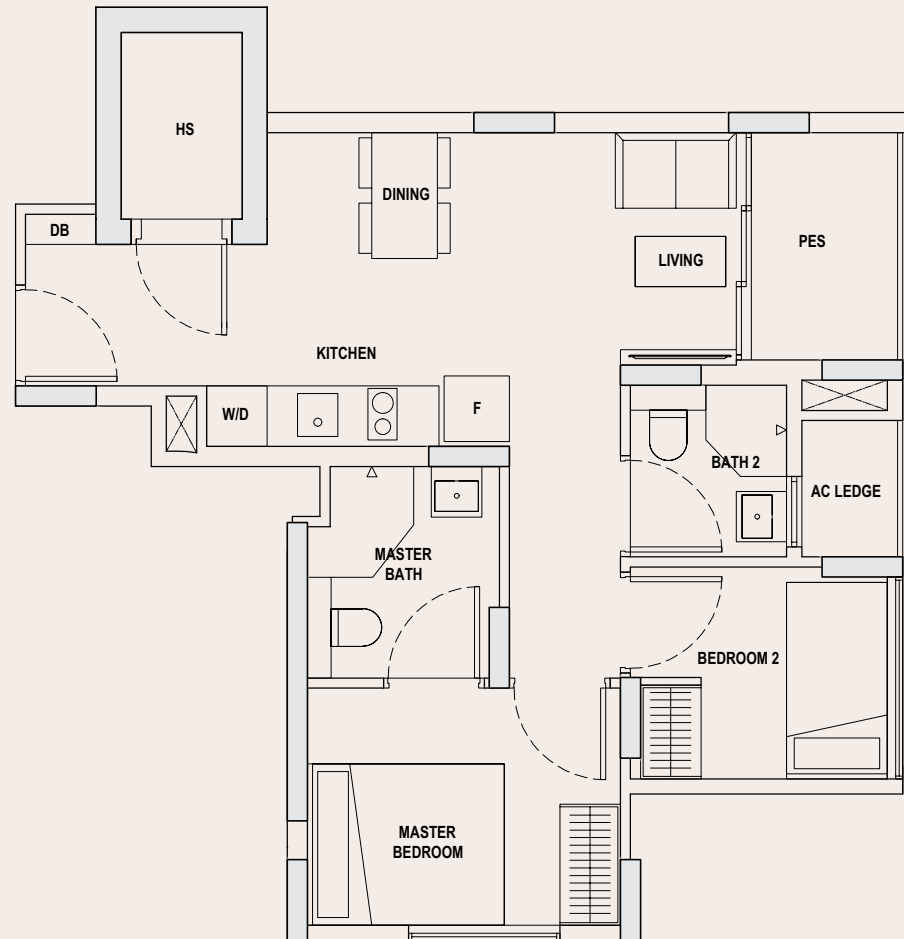

LEGEND

- W/D UNDER-COUNTER WASHER CUM DRYER
- F FRIDGE
- DB DISTRIBUTION BOX
- X VOID SPACE

NOTE:
FOR INFORMATION OF VARYING LENGTH OF DIVIDING WALL BETWEEN ADJACENT UNITS AND/OR FACADE FEATURES VISIBLE TO UNITS, WHERE APPLICABLE, AND NOT DEPICTED IN THE UNIT FLOOR PLAN, PLEASE REFER TO THE RESPECTIVE BLOCK PLAN(S).

AREA INCLUDES A/C LEDGE, BALCONY AND JULIET BALCONY WHERE APPLICABLE. THE ABOVE PLANS AND ILLUSTRATIONS ARE SUBJECT TO CHANGE AS MAY BE REQUIRED OR APPROVED BY THE RELEVANT AUTHORITIES. ALL FLOOR AREAS ARE APPROXIMATE ONLY AND SUBJECT TO FINAL SURVEY. PLEASE REFER TO KEY PLAN FOR ORIENTATION.

BP No.: A2788-03660-2020-BP01 dated 05-06-2023

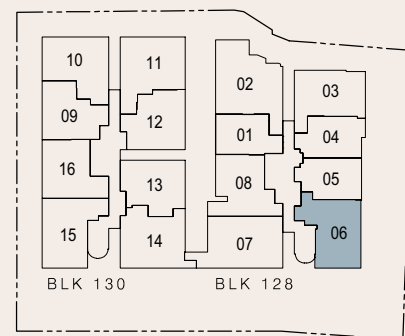

KEY PLAN
NOT DRAWN TO SCALE

2 BEDROOM PREMIUM

TYPE C1b

62 sqm / 667 sqft
(128) #02-06, #03-06, #04-06, #05-06

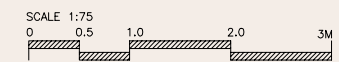
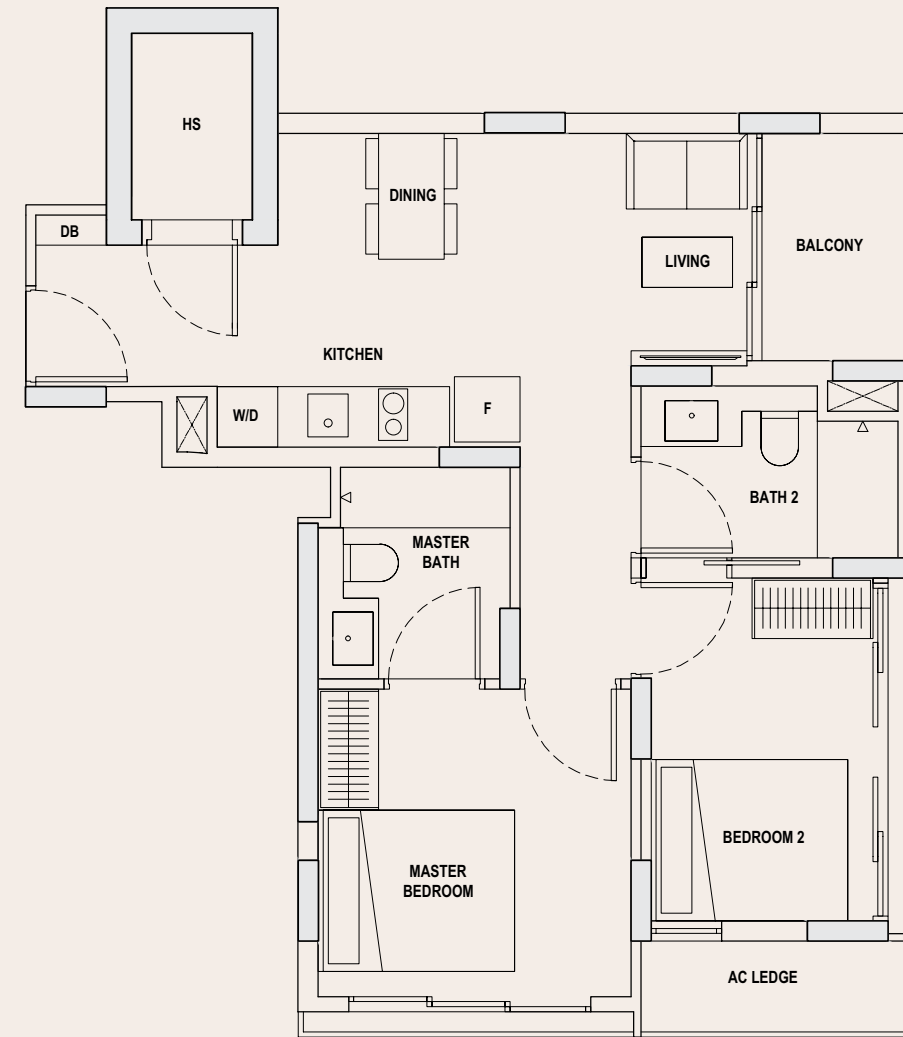

LEGEND

- W/D UNDER-COUNTER WASHER CUM DRYER
- F FRIDGE
- DB DISTRIBUTION BOX
- X VOID SPACE

NOTE:
FOR INFORMATION OF VARYING LENGTH OF DIVIDING WALL BETWEEN ADJACENT UNITS AND/OR FACADE FEATURES VISIBLE TO UNITS, WHERE APPLICABLE, AND NOT DEPICTED IN THE UNIT FLOOR PLAN, PLEASE REFER TO THE RESPECTIVE BLOCK PLAN(S).

AREA INCLUDES A/C LEDGE, BALCONY AND JULIET BALCONY WHERE APPLICABLE. THE ABOVE PLANS AND ILLUSTRATIONS ARE SUBJECT TO CHANGE AS MAY BE REQUIRED OR APPROVED BY THE RELEVANT AUTHORITIES. ALL FLOOR AREAS ARE APPROXIMATE ONLY AND SUBJECT TO FINAL SURVEY. PLEASE REFER TO KEY PLAN FOR ORIENTATION.

BP No.: A2788-03660-2020-BP01 dated 05-06-2023

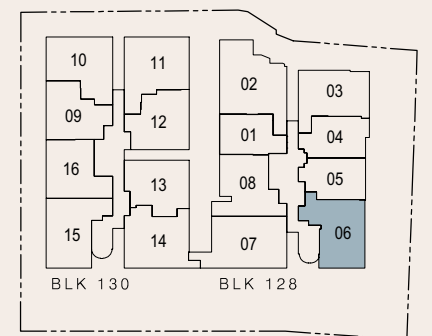

KEY PLAN
NOT DRAWN TO SCALE

TYPE C2a

2 BEDROOM PREMIUM

55 sqm / 592 sqft
(130) #01-16

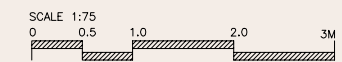
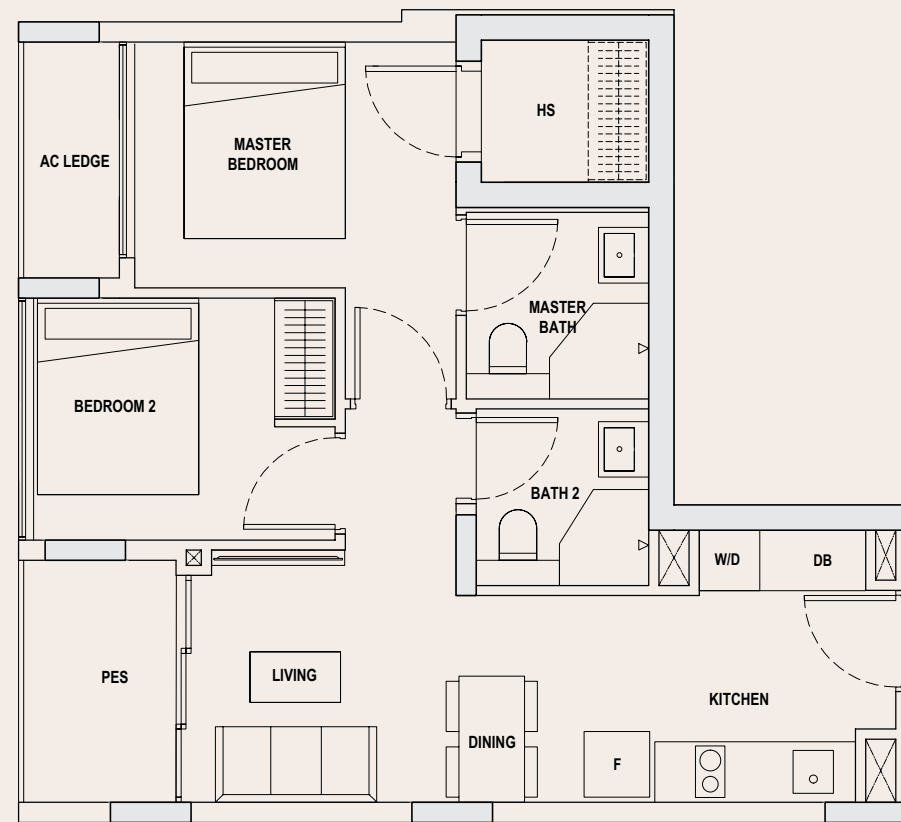

LEGEND

- W/D UNDER-COUNTER WASHER CUM DRYER
- F FRIDGE
- DB DISTRIBUTION BOX
- VOID SPACE

NOTE:
FOR INFORMATION OF VARYING LENGTH OF DIVIDING WALL BETWEEN ADJACENT UNITS AND/OR FACADE FEATURES VISIBLE TO UNITS, WHERE APPLICABLE, AND NOT DEPICTED IN THE UNIT FLOOR PLAN, PLEASE REFER TO THE RESPECTIVE BLOCK PLAN(S).

AREA INCLUDES A/C LEDGE, BALCONY AND JULIET BALCONY WHERE APPLICABLE. THE ABOVE PLANS AND ILLUSTRATIONS ARE SUBJECT TO CHANGE AS MAY BE REQUIRED OR APPROVED BY THE RELEVANT AUTHORITIES. ALL FLOOR AREAS ARE APPROXIMATE ONLY AND SUBJECT TO FINAL SURVEY. PLEASE REFER TO KEY PLAN FOR ORIENTATION.

BP No.: A2788-03660-2020-BP01 dated 05-06-2023

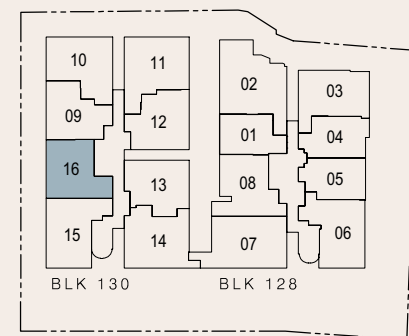

KEY PLAN
NOT DRAWN TO SCALE

2 BEDROOM PREMIUM

TYPE C2b

55 sqm / 592 sqft
(130) #02-16, #03-16, #04-16, #05-16

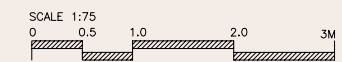
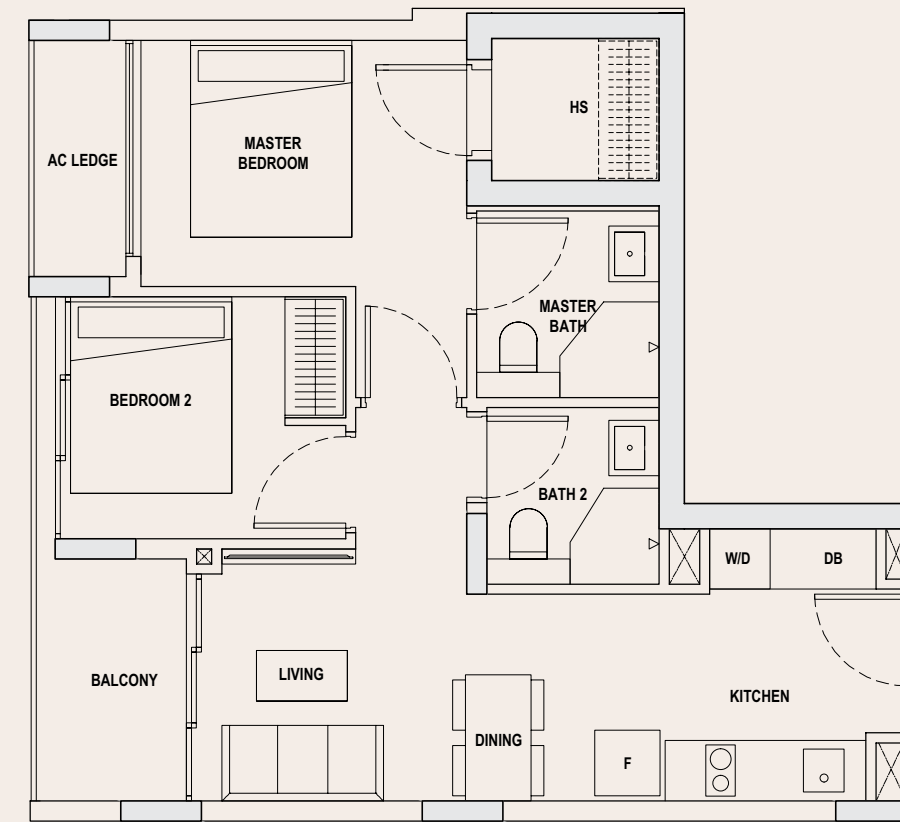

LEGEND

- W/D UNDER-COUNTER WASHER CUM DRYER
- F FRIDGE
- DB DISTRIBUTION BOX
- VOID SPACE

NOTE:
FOR INFORMATION OF VARYING LENGTH OF DIVIDING WALL BETWEEN ADJACENT UNITS AND/OR FACADE FEATURES VISIBLE TO UNITS, WHERE APPLICABLE, AND NOT DEPICTED IN THE UNIT FLOOR PLAN, PLEASE REFER TO THE RESPECTIVE BLOCK PLAN(S).

AREA INCLUDES A/C LEDGE, BALCONY AND JULIET BALCONY WHERE APPLICABLE. THE ABOVE PLANS AND ILLUSTRATIONS ARE SUBJECT TO CHANGE AS MAY BE REQUIRED OR APPROVED BY THE RELEVANT AUTHORITIES. ALL FLOOR AREAS ARE APPROXIMATE ONLY AND SUBJECT TO FINAL SURVEY. PLEASE REFER TO KEY PLAN FOR ORIENTATION.

BP No.: A2788-03660-2020-BP01 dated 05-06-2023

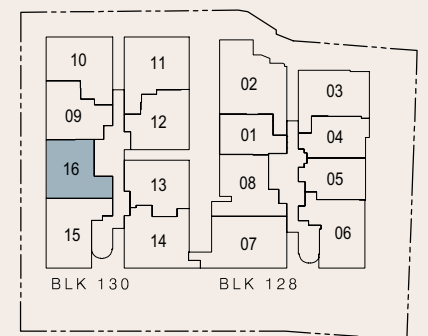

KEY PLAN
NOT DRAWN TO SCALE

TYPE C3a

2 BEDROOM PREMIUM

58 sqm / 624 sqft
(128) #01-03

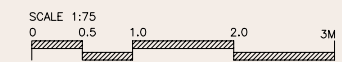
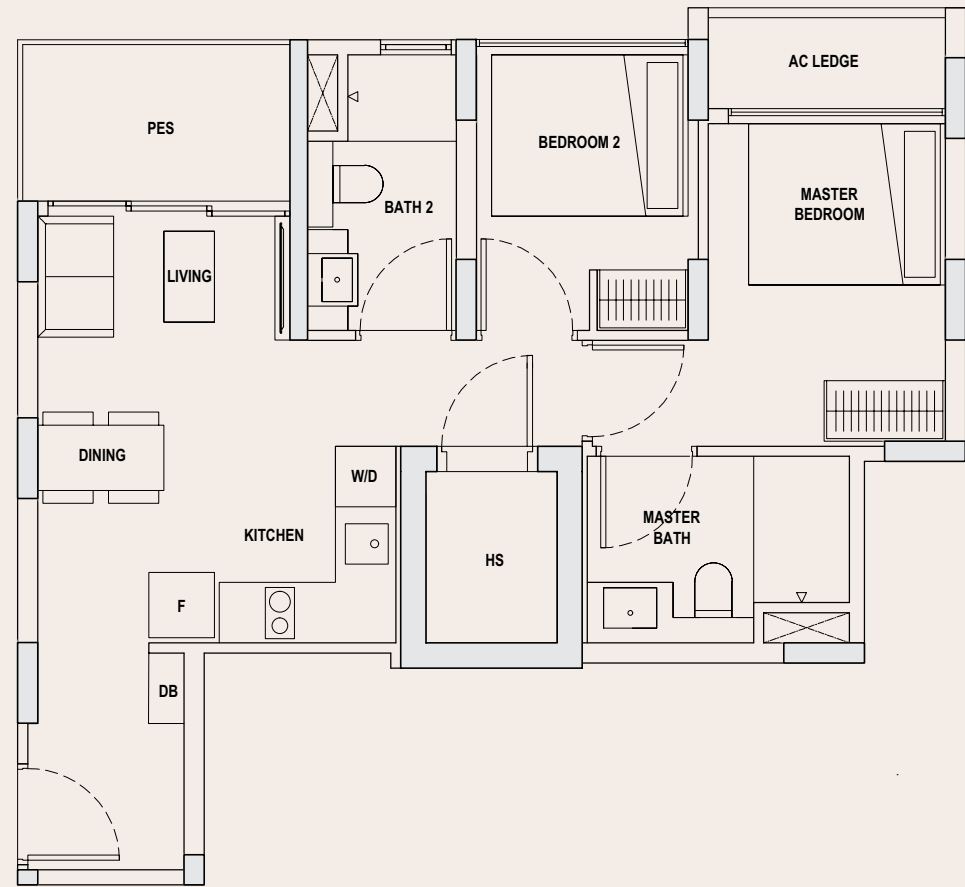

LEGEND

- W/D UNDER-COUNTER WASHER CUM DRYER
- F FRIDGE
- DB DISTRIBUTION BOX
- X VOID SPACE

NOTE:
FOR INFORMATION OF VARYING LENGTH OF DIVIDING WALL BETWEEN ADJACENT UNITS AND/OR FACADE FEATURES VISIBLE TO UNITS, WHERE APPLICABLE, AND NOT DEPICTED IN THE UNIT FLOOR PLAN, PLEASE REFER TO THE RESPECTIVE BLOCK PLAN(S).

AREA INCLUDES A/C LEDGE, BALCONY AND JULIET BALCONY WHERE APPLICABLE. THE ABOVE PLANS AND ILLUSTRATIONS ARE SUBJECT TO CHANGE AS MAY BE REQUIRED OR APPROVED BY THE RELEVANT AUTHORITIES. ALL FLOOR AREAS ARE APPROXIMATE ONLY AND SUBJECT TO FINAL SURVEY. PLEASE REFER TO KEY PLAN FOR ORIENTATION.

BP No.: A2788-03660-2020-BP01 dated 05-06-2023

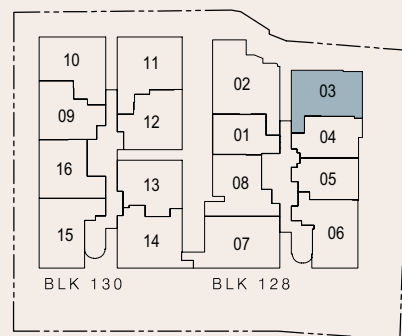

KEY PLAN
NOT DRAWN TO SCALE

2 BEDROOM PREMIUM

TYPE C3b

59 sqm / 635 sqft
(128) #02-03, #03-03, #04-03, #05-03

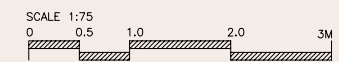
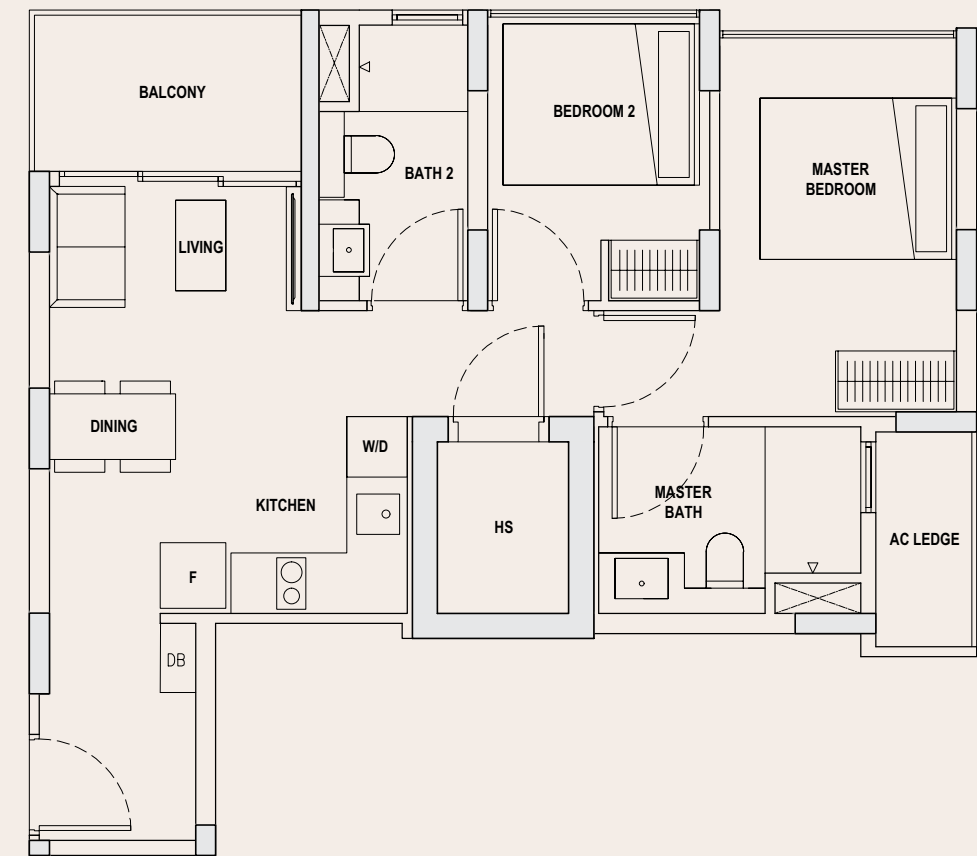

LEGEND

- W/D UNDER-COUNTER WASHER CUM DRYER
- F FRIDGE
- DB DISTRIBUTION BOX
- X VOID SPACE

NOTE:
FOR INFORMATION OF VARYING LENGTH OF DIVIDING WALL BETWEEN ADJACENT UNITS AND/OR FACADE FEATURES VISIBLE TO UNITS, WHERE APPLICABLE, AND NOT DEPICTED IN THE UNIT FLOOR PLAN, PLEASE REFER TO THE RESPECTIVE BLOCK PLAN(S).

AREA INCLUDES A/C LEDGE, BALCONY AND JULIET BALCONY WHERE APPLICABLE. THE ABOVE PLANS AND ILLUSTRATIONS ARE SUBJECT TO CHANGE AS MAY BE REQUIRED OR APPROVED BY THE RELEVANT AUTHORITIES. ALL FLOOR AREAS ARE APPROXIMATE ONLY AND SUBJECT TO FINAL SURVEY. PLEASE REFER TO KEY PLAN FOR ORIENTATION.

BP No.: A2788-03660-2020-BP01 dated 05-06-2023

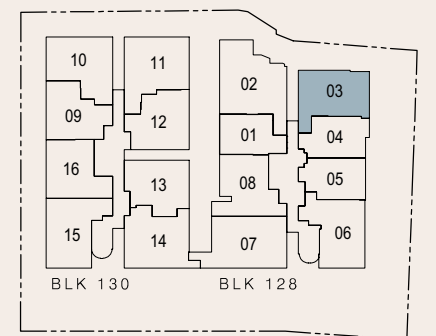

KEY PLAN
NOT DRAWN TO SCALE

TYPE C4

2 BEDROOM PREMIUM

56 sqm / 603 sqft
(130) #01-12, #02-12, #03-12, #04-12, #05-12

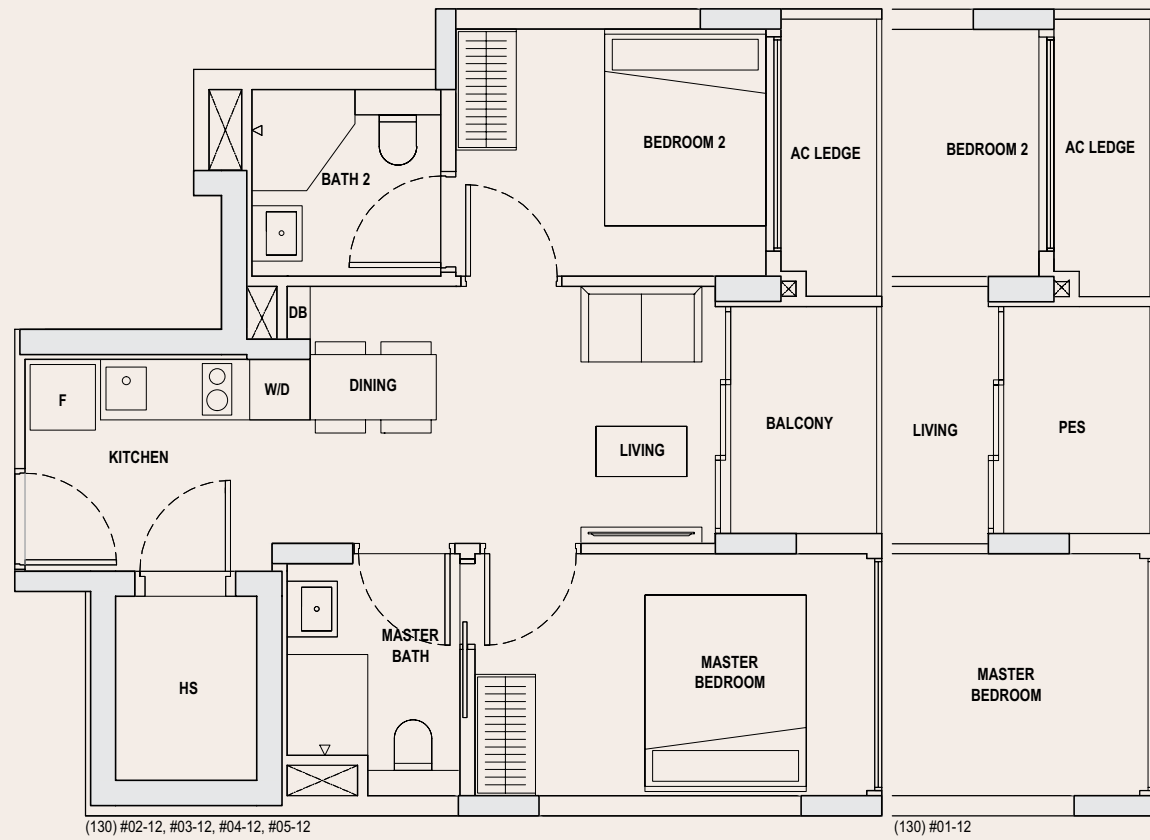

2 BEDROOM PREMIUM

TYPE C5a

60 sqm / 646 sqft
(130) #01-10

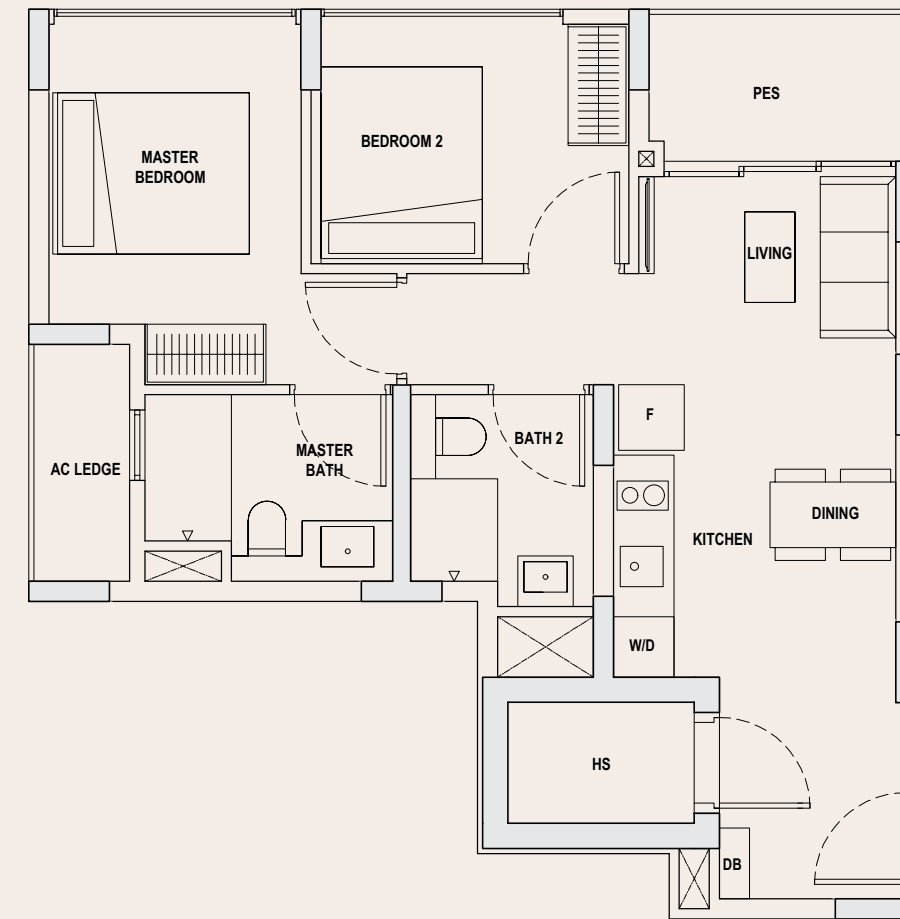

LEGEND

- W/D UNDER-COUNTER WASHER CUM DRYER
- F FRIDGE
- DB DISTRIBUTION BOX
- X VOID SPACE

NOTE:
FOR INFORMATION OF VARYING LENGTH OF DIVIDING WALL BETWEEN ADJACENT UNITS AND/OR FACADE FEATURES VISIBLE TO UNITS, WHERE APPLICABLE, AND NOT DEPICTED IN THE UNIT FLOOR PLAN, PLEASE REFER TO THE RESPECTIVE BLOCK PLAN(S).

AREA INCLUDES A/C LEDGE, BALCONY AND JULIET BALCONY WHERE APPLICABLE. THE ABOVE PLANS AND ILLUSTRATIONS ARE SUBJECT TO CHANGE AS MAY BE REQUIRED OR APPROVED BY THE RELEVANT AUTHORITIES. ALL FLOOR AREAS ARE APPROXIMATE ONLY AND SUBJECT TO FINAL SURVEY. PLEASE REFER TO KEY PLAN FOR ORIENTATION.

BP No.: A2788-03660-2020-BP01 dated 05-06-2023

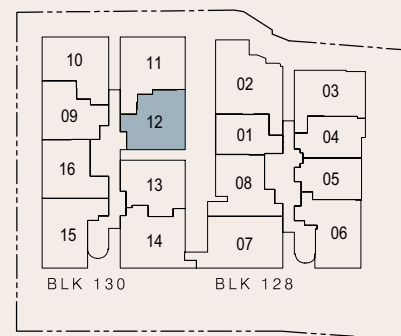

KEY PLAN
NOT DRAWN TO SCALE

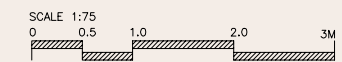

LEGEND

- W/D UNDER-COUNTER WASHER CUM DRYER
- F FRIDGE
- DB DISTRIBUTION BOX
- X VOID SPACE

NOTE:
FOR INFORMATION OF VARYING LENGTH OF DIVIDING WALL BETWEEN ADJACENT UNITS AND/OR FACADE FEATURES VISIBLE TO UNITS, WHERE APPLICABLE, AND NOT DEPICTED IN THE UNIT FLOOR PLAN, PLEASE REFER TO THE RESPECTIVE BLOCK PLAN(S).

AREA INCLUDES A/C LEDGE, BALCONY AND JULIET BALCONY WHERE APPLICABLE. THE ABOVE PLANS AND ILLUSTRATIONS ARE SUBJECT TO CHANGE AS MAY BE REQUIRED OR APPROVED BY THE RELEVANT AUTHORITIES. ALL FLOOR AREAS ARE APPROXIMATE ONLY AND SUBJECT TO FINAL SURVEY. PLEASE REFER TO KEY PLAN FOR ORIENTATION.

BP No.: A2788-03660-2020-BP01 dated 05-06-2023

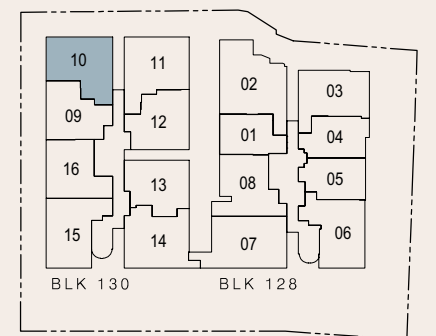

KEY PLAN
NOT DRAWN TO SCALE

TYPE C5b

2 BEDROOM PREMIUM

60 sqm / 646 sqft
(130) #02-10, #03-10, #04-10, #05-10

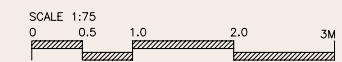
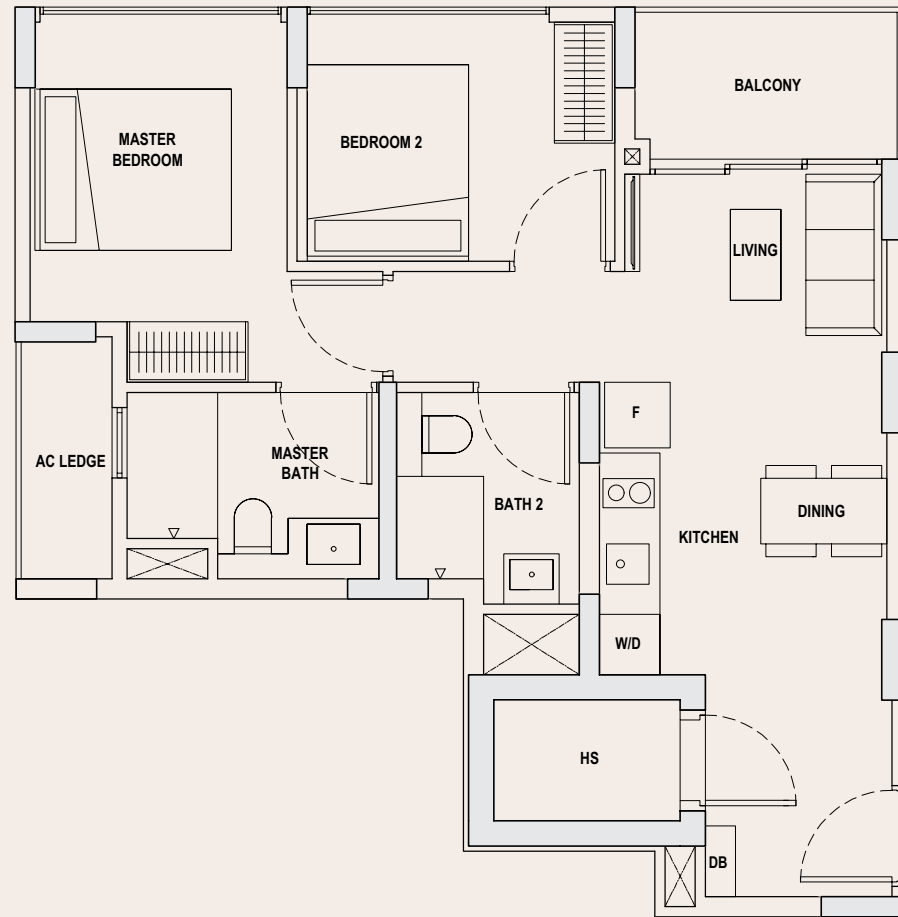

LEGEND

- W/D UNDER-COUNTER WASHER CUM DRYER
- F FRIDGE
- DB DISTRIBUTION BOX
- X VOID SPACE

NOTE: FOR INFORMATION OF VARYING LENGTH OF DIVIDING WALL BETWEEN ADJACENT UNITS AND/OR FACADE FEATURES VISIBLE TO UNITS, WHERE APPLICABLE, AND NOT DEPICTED IN THE UNIT FLOOR PLAN, PLEASE REFER TO THE RESPECTIVE BLOCK PLAN(S).

AREA INCLUDES A/C LEDGE, BALCONY AND JULIET BALCONY WHERE APPLICABLE. THE ABOVE PLANS AND ILLUSTRATIONS ARE SUBJECT TO CHANGE AS MAY BE REQUIRED OR APPROVED BY THE RELEVANT AUTHORITIES. ALL FLOOR AREAS ARE APPROXIMATE ONLY AND SUBJECT TO FINAL SURVEY. PLEASE REFER TO KEY PLAN FOR ORIENTATION.

BP No.: A2788-03660-2020-BP01 dated 05-06-2023

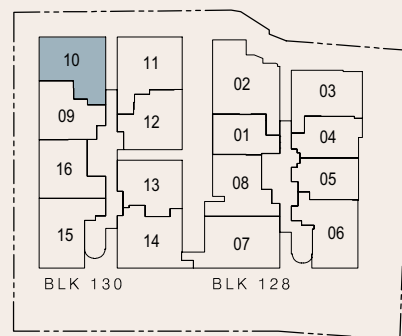

KEY PLAN

NOT DRAWN TO SCALE

2 BEDROOM PREMIUM

TYPE C6a

59 sqm / 635 sqft
(130) #01-15

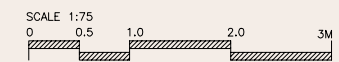
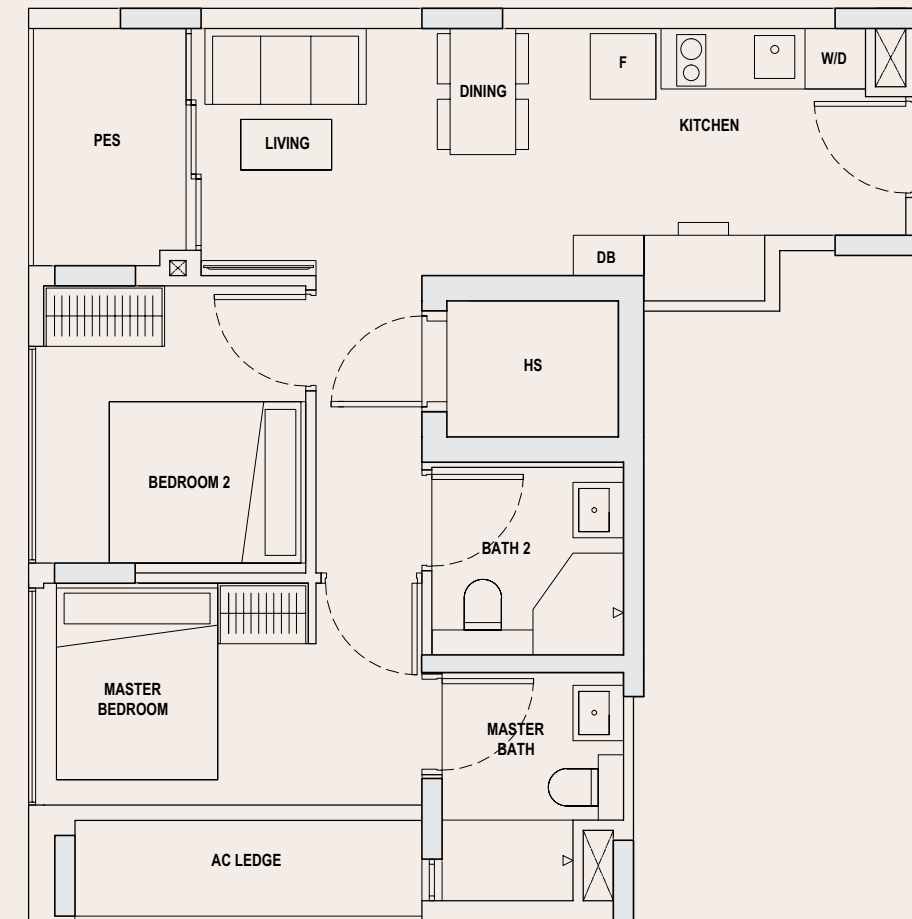

LEGEND

- W/D UNDER-COUNTER WASHER CUM DRYER
- F FRIDGE
- DB DISTRIBUTION BOX
- X VOID SPACE

NOTE: FOR INFORMATION OF VARYING LENGTH OF DIVIDING WALL BETWEEN ADJACENT UNITS AND/OR FACADE FEATURES VISIBLE TO UNITS, WHERE APPLICABLE, AND NOT DEPICTED IN THE UNIT FLOOR PLAN, PLEASE REFER TO THE RESPECTIVE BLOCK PLAN(S).

AREA INCLUDES A/C LEDGE, BALCONY AND JULIET BALCONY WHERE APPLICABLE. THE ABOVE PLANS AND ILLUSTRATIONS ARE SUBJECT TO CHANGE AS MAY BE REQUIRED OR APPROVED BY THE RELEVANT AUTHORITIES. ALL FLOOR AREAS ARE APPROXIMATE ONLY AND SUBJECT TO FINAL SURVEY. PLEASE REFER TO KEY PLAN FOR ORIENTATION.

BP No.: A2788-03660-2020-BP01 dated 05-06-2023

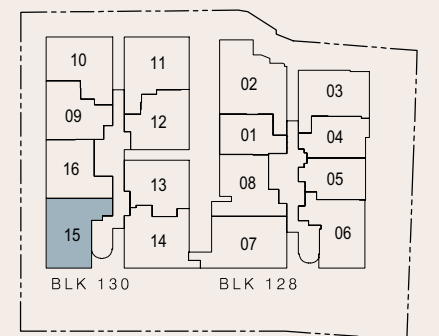

KEY PLAN

NOT DRAWN TO SCALE

TYPE C6b

2 BEDROOM PREMIUM

61 sqm / 657 sqft
(130) #02-15, #03-15, #04-15, #05-15

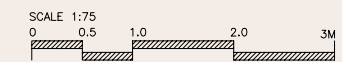
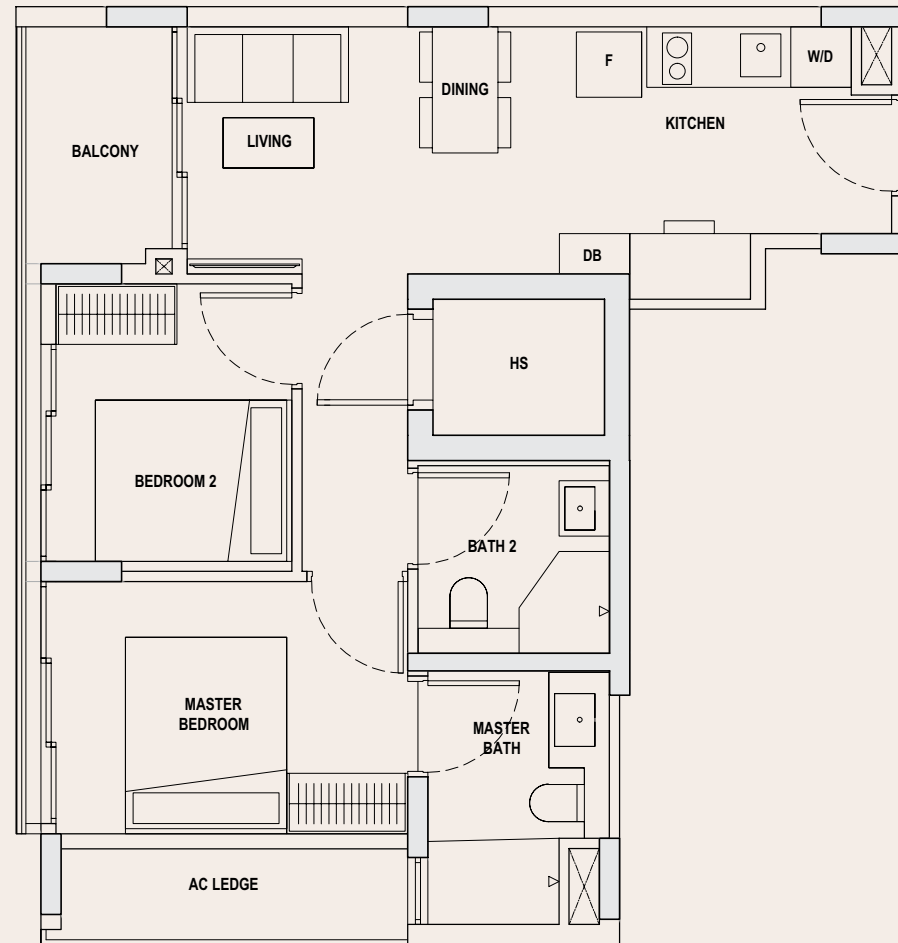

LEGEND

- W/D UNDER-COUNTER WASHER CUM DRYER
- F FRIDGE
- DB DISTRIBUTION BOX
- X VOID SPACE

NOTE:
FOR INFORMATION OF VARYING LENGTH OF DIVIDING WALL BETWEEN ADJACENT UNITS AND/OR FACADE FEATURES VISIBLE TO UNITS, WHERE APPLICABLE, AND NOT DEPICTED IN THE UNIT FLOOR PLAN, PLEASE REFER TO THE RESPECTIVE BLOCK PLAN(S).

AREA INCLUDES A/C LEDGE, BALCONY AND JULIET BALCONY WHERE APPLICABLE. THE ABOVE PLANS AND ILLUSTRATIONS ARE SUBJECT TO CHANGE AS MAY BE REQUIRED OR APPROVED BY THE RELEVANT AUTHORITIES. ALL FLOOR AREAS ARE APPROXIMATE ONLY AND SUBJECT TO FINAL SURVEY. PLEASE REFER TO KEY PLAN FOR ORIENTATION.

BP No.: A2788-03660-2020-BP01 dated 05-06-2023

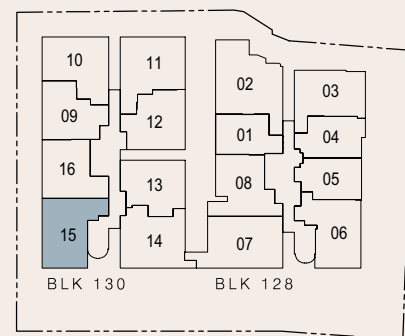

KEY PLAN
NOT DRAWN TO SCALE

2 BEDROOM PREMIUM

TYPE C7a

60 sqm / 646 sqft
(130) #01-14

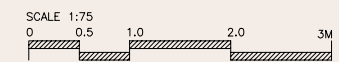
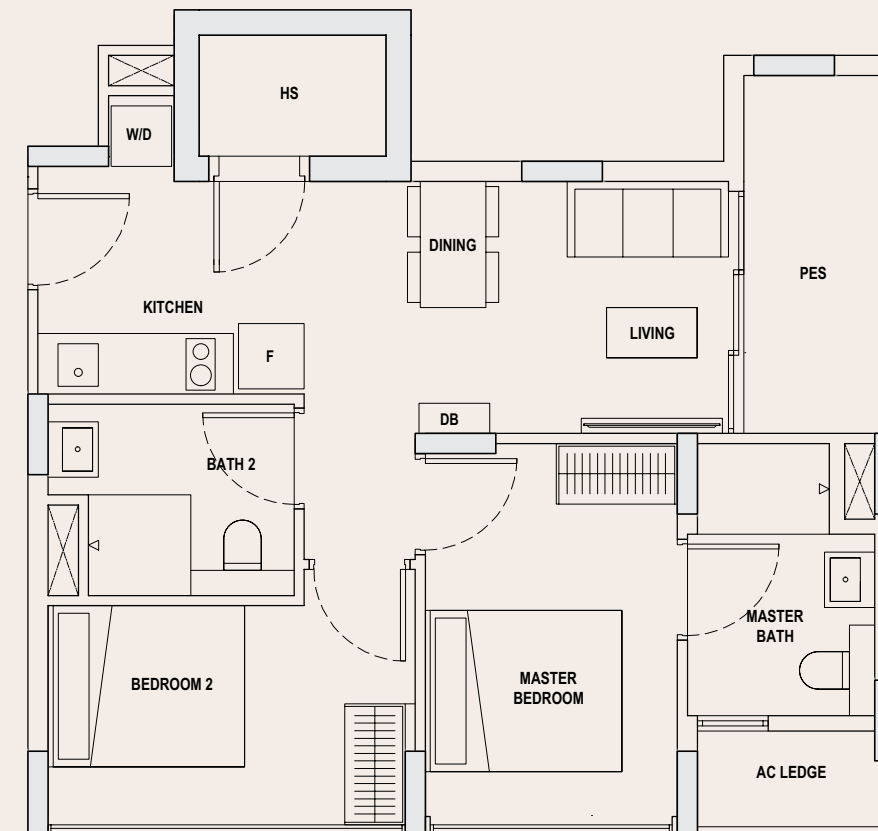

LEGEND

- W/D UNDER-COUNTER WASHER CUM DRYER
- F FRIDGE
- DB DISTRIBUTION BOX
- X VOID SPACE

NOTE:
FOR INFORMATION OF VARYING LENGTH OF DIVIDING WALL BETWEEN ADJACENT UNITS AND/OR FACADE FEATURES VISIBLE TO UNITS, WHERE APPLICABLE, AND NOT DEPICTED IN THE UNIT FLOOR PLAN, PLEASE REFER TO THE RESPECTIVE BLOCK PLAN(S).

AREA INCLUDES A/C LEDGE, BALCONY AND JULIET BALCONY WHERE APPLICABLE. THE ABOVE PLANS AND ILLUSTRATIONS ARE SUBJECT TO CHANGE AS MAY BE REQUIRED OR APPROVED BY THE RELEVANT AUTHORITIES. ALL FLOOR AREAS ARE APPROXIMATE ONLY AND SUBJECT TO FINAL SURVEY. PLEASE REFER TO KEY PLAN FOR ORIENTATION.

BP No.: A2788-03660-2020-BP01 dated 05-06-2023

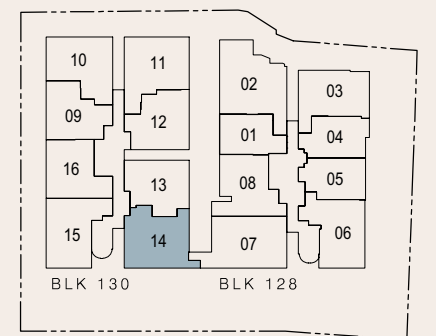

KEY PLAN
NOT DRAWN TO SCALE

TYPE C7b

2 BEDROOM PREMIUM

64 sqm / 689 sqft
(130) #02-14, #03-14, #04-14, #05-14

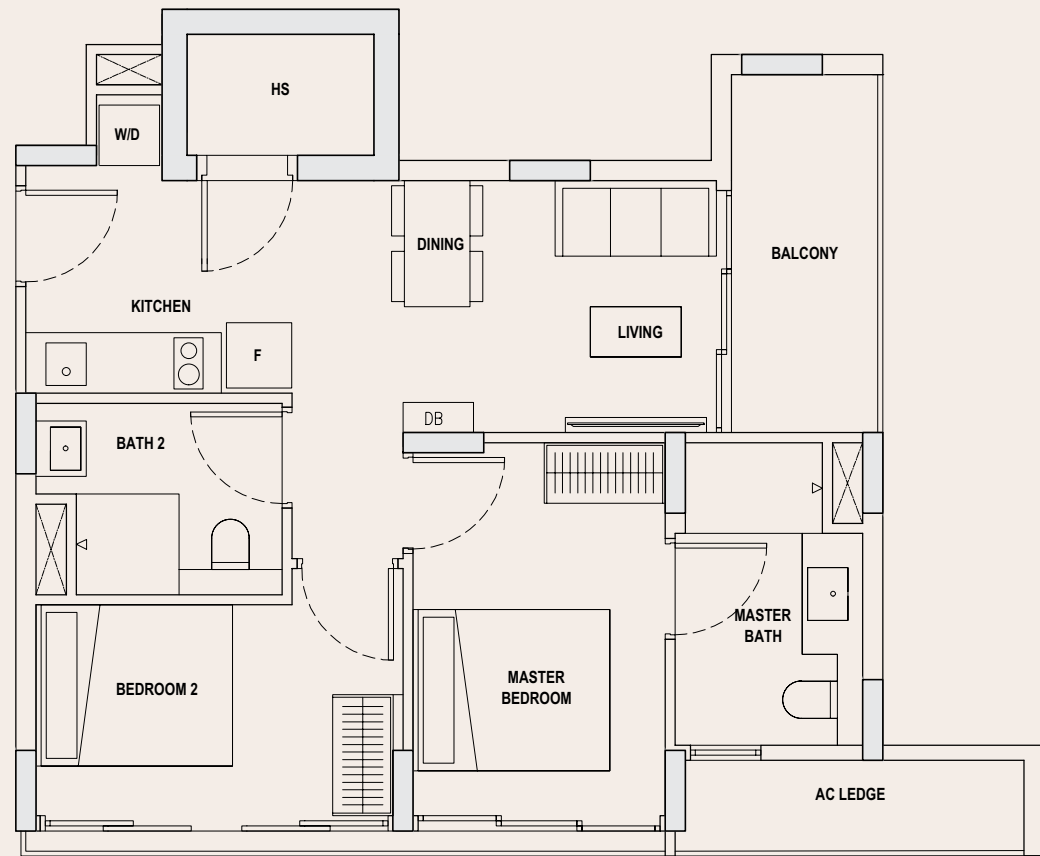

2 BEDROOM PREMIUM

TYPE C8

59 sqm / 635 sqft
(128) #01-08, #02-08, #03-08, #04-08, #05-08

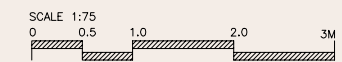
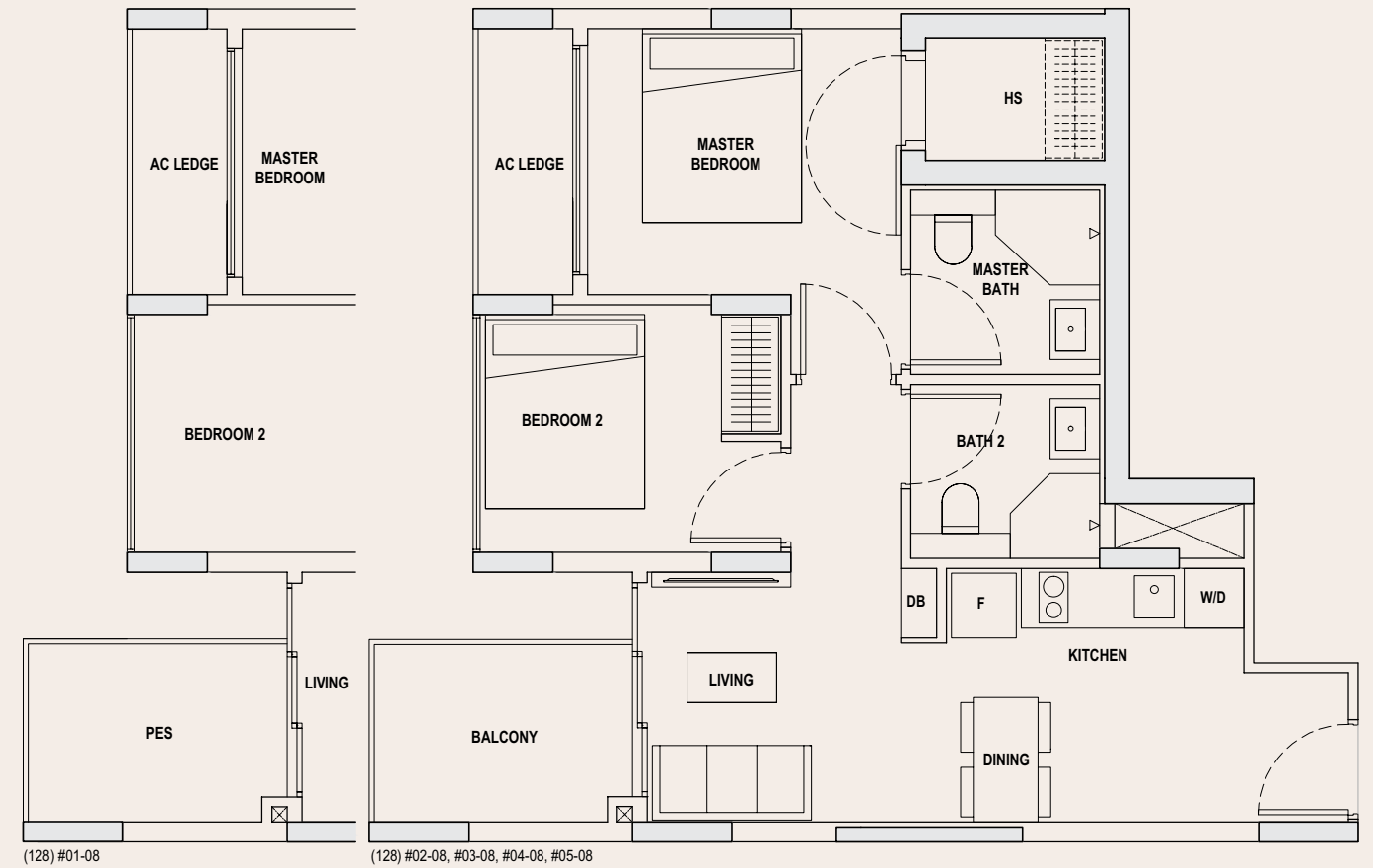

- LEGEND**
- UNDER-COUNTER WASHER CUM DRYER
 - FRIDGE
 - DISTRIBUTION BOX
 - VOID SPACE

NOTE:
FOR INFORMATION OF VARYING LENGTH OF DIVIDING WALL BETWEEN ADJACENT UNITS AND/OR FACADE FEATURES VISIBLE TO UNITS, WHERE APPLICABLE, AND NOT DEPICTED IN THE UNIT FLOOR PLAN, PLEASE REFER TO THE RESPECTIVE BLOCK PLAN(S).

AREA INCLUDES A/C LEDGE, BALCONY AND JULIET BALCONY WHERE APPLICABLE. THE ABOVE PLANS AND ILLUSTRATIONS ARE SUBJECT TO CHANGE AS MAY BE REQUIRED OR APPROVED BY THE RELEVANT AUTHORITIES. ALL FLOOR AREAS ARE APPROXIMATE ONLY AND SUBJECT TO FINAL SURVEY. PLEASE REFER TO KEY PLAN FOR ORIENTATION.

BP No.: A2788-03660-2020-BP01 dated 05-06-2023

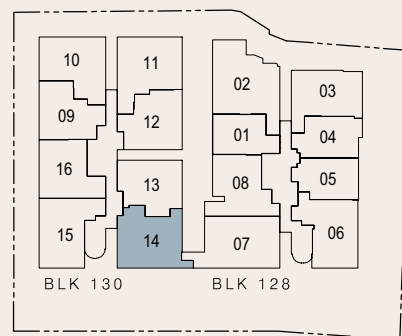

KEY PLAN
NOT DRAWN TO SCALE

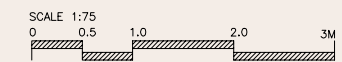

- LEGEND**
- UNDER-COUNTER WASHER CUM DRYER
 - FRIDGE
 - DISTRIBUTION BOX
 - VOID SPACE

NOTE:
FOR INFORMATION OF VARYING LENGTH OF DIVIDING WALL BETWEEN ADJACENT UNITS AND/OR FACADE FEATURES VISIBLE TO UNITS, WHERE APPLICABLE, AND NOT DEPICTED IN THE UNIT FLOOR PLAN, PLEASE REFER TO THE RESPECTIVE BLOCK PLAN(S).

AREA INCLUDES A/C LEDGE, BALCONY AND JULIET BALCONY WHERE APPLICABLE. THE ABOVE PLANS AND ILLUSTRATIONS ARE SUBJECT TO CHANGE AS MAY BE REQUIRED OR APPROVED BY THE RELEVANT AUTHORITIES. ALL FLOOR AREAS ARE APPROXIMATE ONLY AND SUBJECT TO FINAL SURVEY. PLEASE REFER TO KEY PLAN FOR ORIENTATION.

BP No.: A2788-03660-2020-BP01 dated 05-06-2023

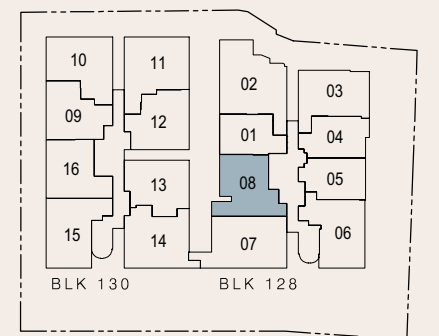

KEY PLAN
NOT DRAWN TO SCALE

TYPE C9a

2 BEDROOM PRESTIGE

66 sqm / 710 sqft
(130) #01-11

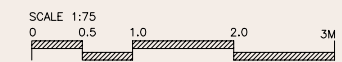
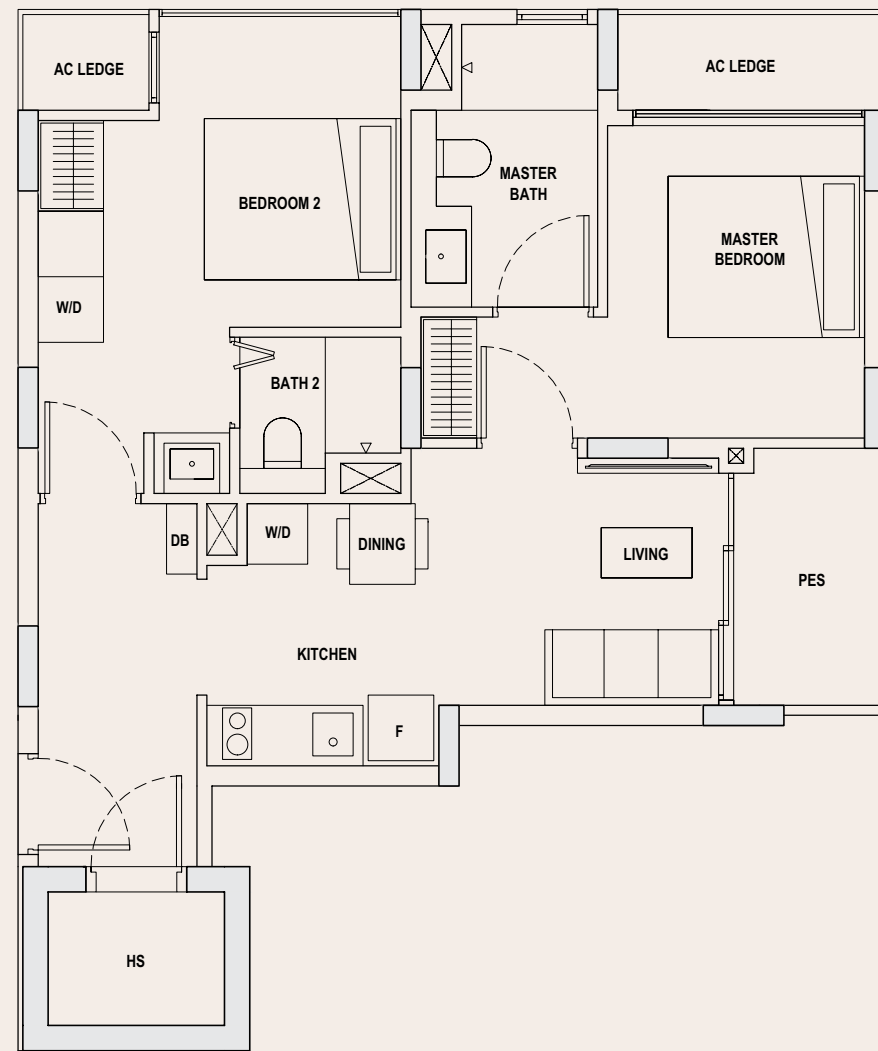

LEGEND

- W/D UNDER-COUNTER WASHER CUM DRYER
- F FRIDGE
- DB DISTRIBUTION BOX
- X VOID SPACE

NOTE: FOR INFORMATION OF VARYING LENGTH OF DIVIDING WALL BETWEEN ADJACENT UNITS AND/OR FACADE FEATURES VISIBLE TO UNITS, WHERE APPLICABLE, AND NOT DEPICTED IN THE UNIT FLOOR PLAN, PLEASE REFER TO THE RESPECTIVE BLOCK PLAN(S).

AREA INCLUDES A/C LEDGE, BALCONY AND JULIET BALCONY WHERE APPLICABLE. THE ABOVE PLANS AND ILLUSTRATIONS ARE SUBJECT TO CHANGE AS MAY BE REQUIRED OR APPROVED BY THE RELEVANT AUTHORITIES. ALL FLOOR AREAS ARE APPROXIMATE ONLY AND SUBJECT TO FINAL SURVEY. PLEASE REFER TO KEY PLAN FOR ORIENTATION.

BP No.: A2788-03660-2020-BP01 dated 05-06-2023

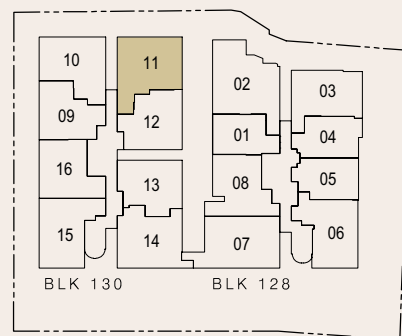

KEY PLAN
NOT DRAWN TO SCALE

2 BEDROOM PRESTIGE

TYPE C9b

66 sqm / 710 sqft
(130) #02-11, #03-11, #04-11, #05-11

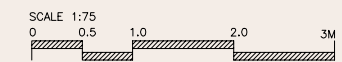
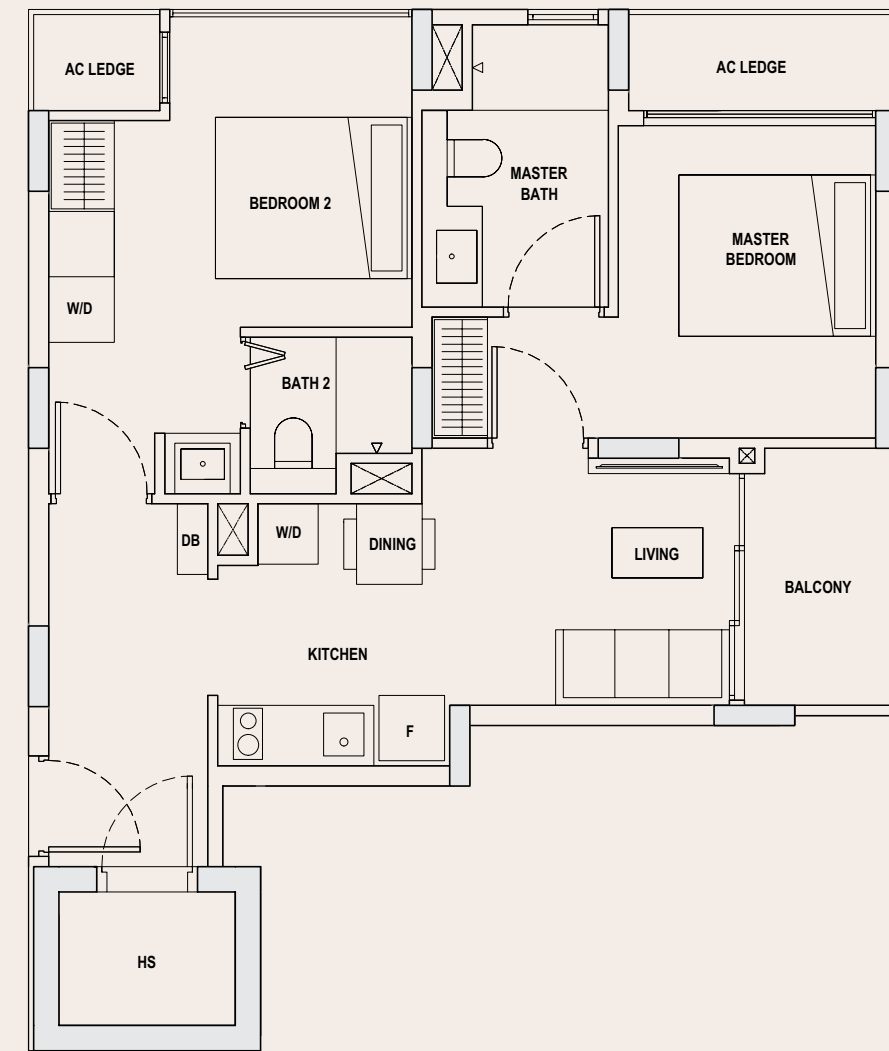

LEGEND

- W/D UNDER-COUNTER WASHER CUM DRYER
- F FRIDGE
- DB DISTRIBUTION BOX
- X VOID SPACE

NOTE: FOR INFORMATION OF VARYING LENGTH OF DIVIDING WALL BETWEEN ADJACENT UNITS AND/OR FACADE FEATURES VISIBLE TO UNITS, WHERE APPLICABLE, AND NOT DEPICTED IN THE UNIT FLOOR PLAN, PLEASE REFER TO THE RESPECTIVE BLOCK PLAN(S).

AREA INCLUDES A/C LEDGE, BALCONY AND JULIET BALCONY WHERE APPLICABLE. THE ABOVE PLANS AND ILLUSTRATIONS ARE SUBJECT TO CHANGE AS MAY BE REQUIRED OR APPROVED BY THE RELEVANT AUTHORITIES. ALL FLOOR AREAS ARE APPROXIMATE ONLY AND SUBJECT TO FINAL SURVEY. PLEASE REFER TO KEY PLAN FOR ORIENTATION.

BP No.: A2788-03660-2020-BP01 dated 05-06-2023

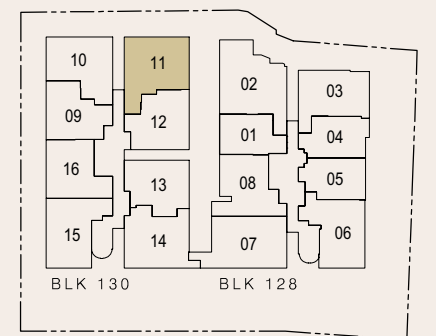

KEY PLAN
NOT DRAWN TO SCALE

TYPE D1

3 BEDROOM

71sqm / 764 sqft
(128) #03-07, #04-07, #05-07

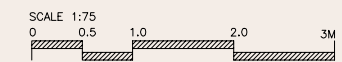
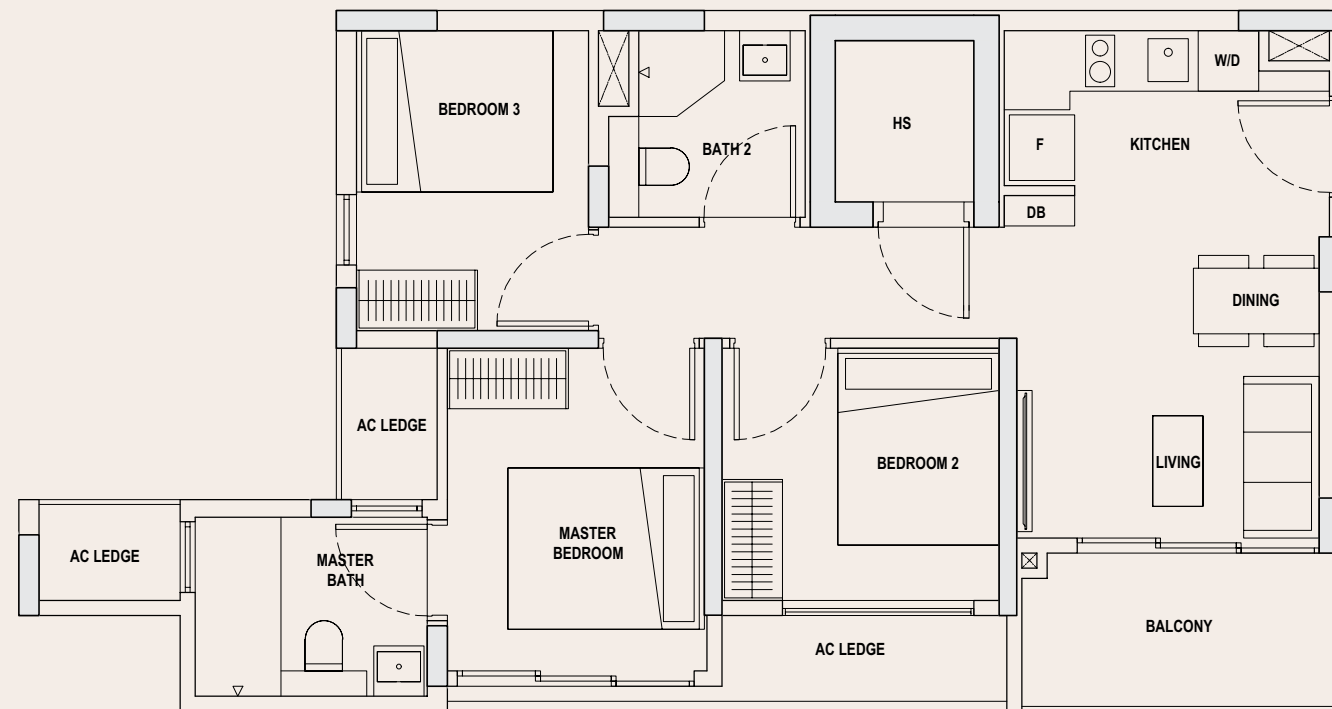

- LEGEND**
- UNDER-COUNTER WASHER CUM DRYER
 - FRIDGE
 - DISTRIBUTION BOX
 - VOID SPACE

NOTE:
FOR INFORMATION OF VARYING LENGTH OF DIVIDING WALL BETWEEN ADJACENT UNITS AND/OR FACADE FEATURES VISIBLE TO UNITS, WHERE APPLICABLE, AND NOT DEPICTED IN THE UNIT FLOOR PLAN, PLEASE REFER TO THE RESPECTIVE BLOCK PLAN(S).

AREA INCLUDES A/C LEDGE, BALCONY AND JULIET BALCONY WHERE APPLICABLE. THE ABOVE PLANS AND ILLUSTRATIONS ARE SUBJECT TO CHANGE AS MAY BE REQUIRED OR APPROVED BY THE RELEVANT AUTHORITIES. ALL FLOOR AREAS ARE APPROXIMATE ONLY AND SUBJECT TO FINAL SURVEY. PLEASE REFER TO KEY PLAN FOR ORIENTATION.

BP No.: A2788-03660-2020-BP01 dated 05-06-2023

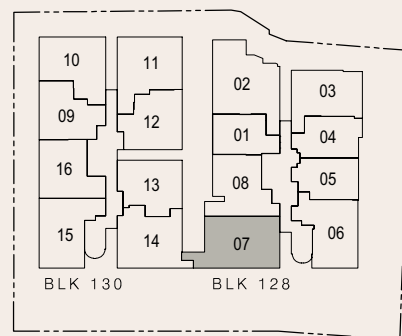

KEY PLAN
NOT DRAWN TO SCALE

3 BEDROOM DUAL KEY

TYPE DK2a

77 sqm / 829 sqft
(128) #01-02

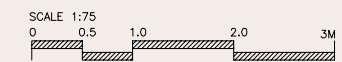
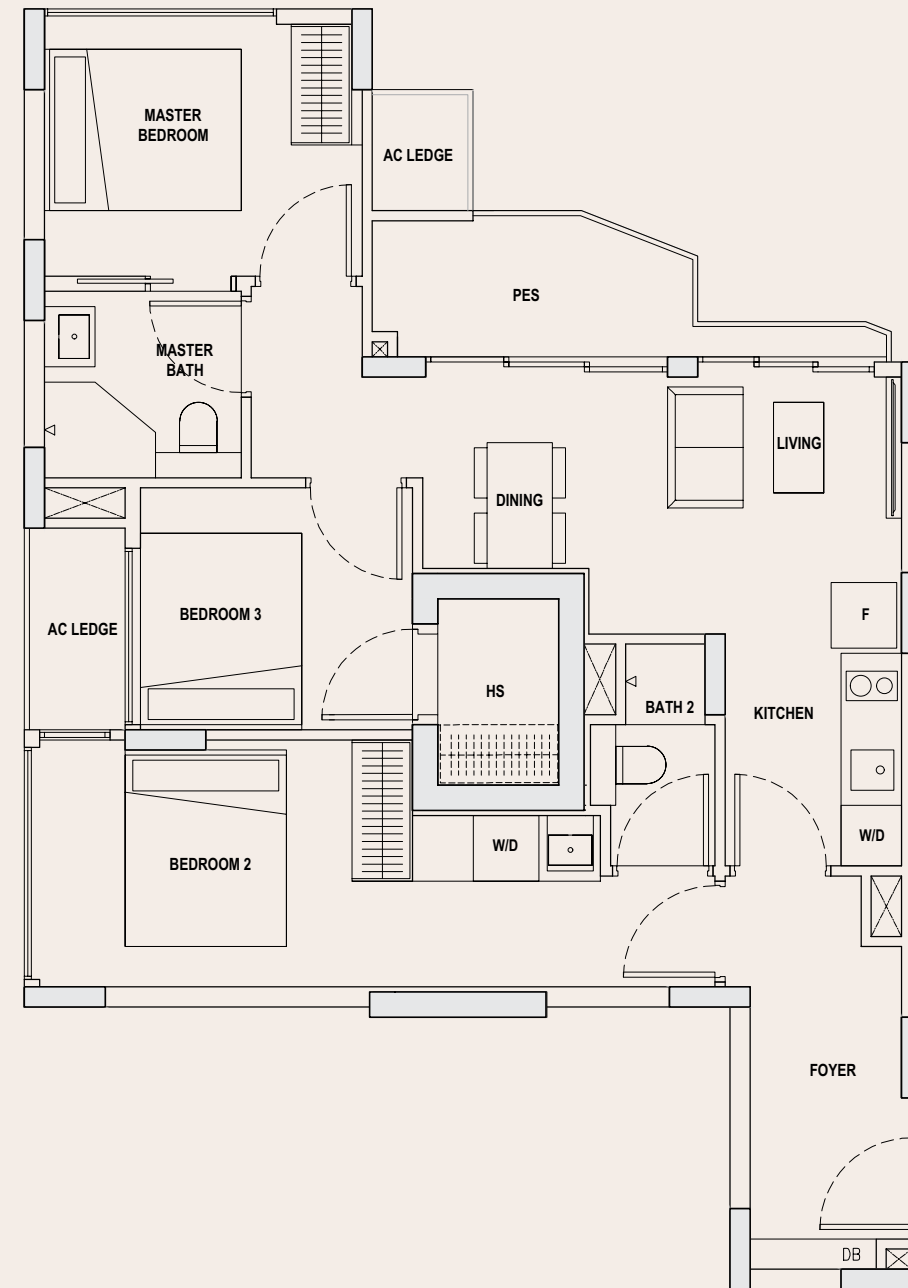

- LEGEND**
- UNDER-COUNTER WASHER CUM DRYER
 - FRIDGE
 - DISTRIBUTION BOX
 - VOID SPACE

NOTE:
FOR INFORMATION OF VARYING LENGTH OF DIVIDING WALL BETWEEN ADJACENT UNITS AND/OR FACADE FEATURES VISIBLE TO UNITS, WHERE APPLICABLE, AND NOT DEPICTED IN THE UNIT FLOOR PLAN, PLEASE REFER TO THE RESPECTIVE BLOCK PLAN(S).

AREA INCLUDES A/C LEDGE, BALCONY AND JULIET BALCONY WHERE APPLICABLE. THE ABOVE PLANS AND ILLUSTRATIONS ARE SUBJECT TO CHANGE AS MAY BE REQUIRED OR APPROVED BY THE RELEVANT AUTHORITIES. ALL FLOOR AREAS ARE APPROXIMATE ONLY AND SUBJECT TO FINAL SURVEY. PLEASE REFER TO KEY PLAN FOR ORIENTATION.

BP No.: A2788-03660-2020-BP01 dated 05-06-2023

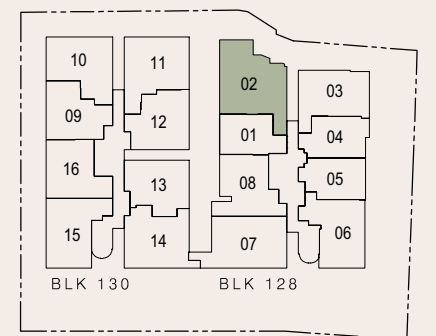

KEY PLAN
NOT DRAWN TO SCALE

TYPE DK2b

3 BEDROOM DUAL KEY

78 sqm / 840 sqft
 (128) #02-02, #03-02, #04-02, #05-02

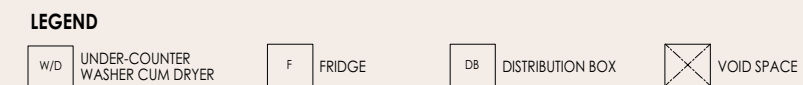
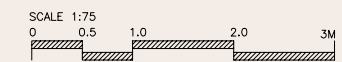
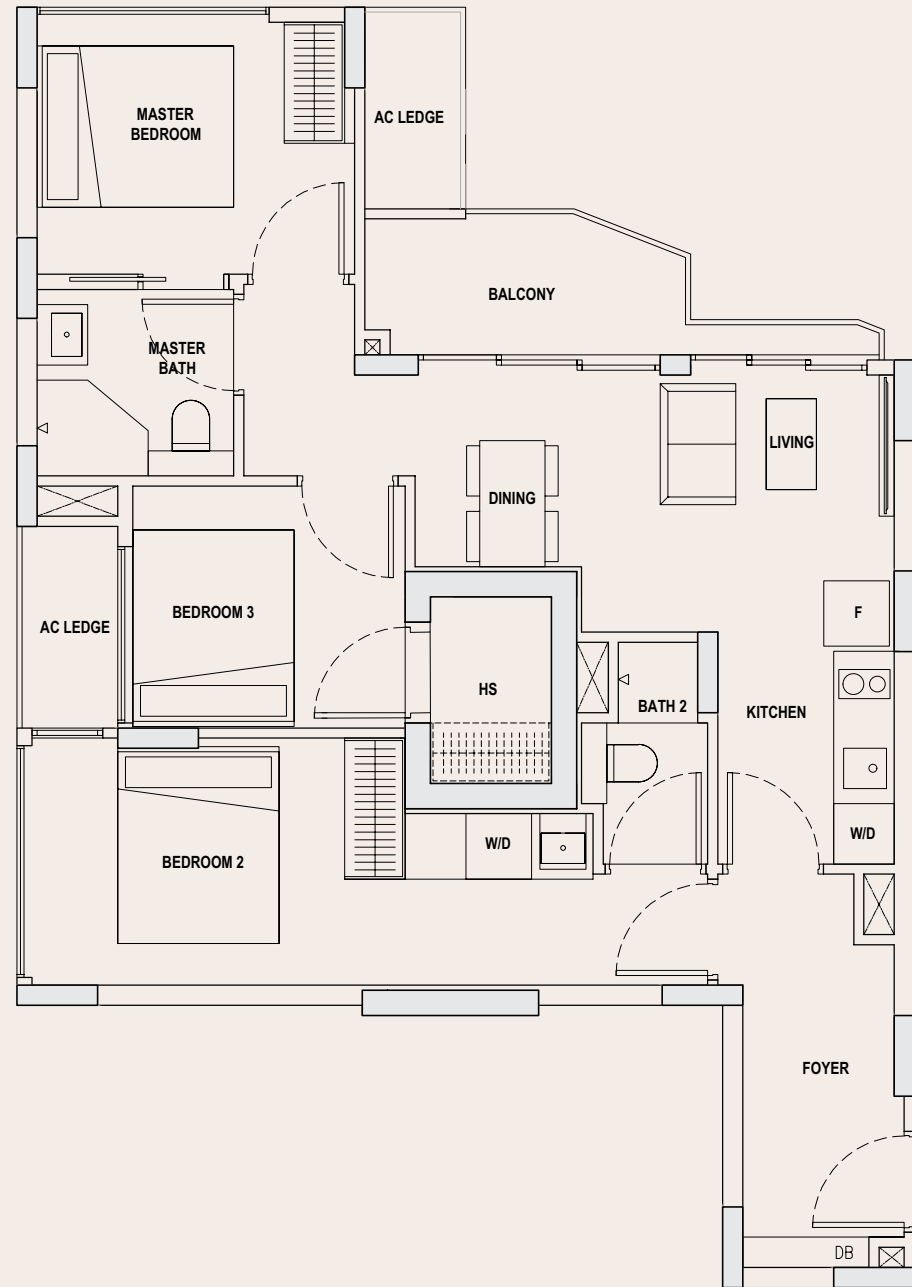

NOTE:
 FOR INFORMATION OF VARYING LENGTH OF DIVIDING WALL BETWEEN ADJACENT UNITS AND/OR FACADE FEATURES VISIBLE TO UNITS, WHERE APPLICABLE, AND NOT DEPICTED IN THE UNIT FLOOR PLAN, PLEASE REFER TO THE RESPECTIVE BLOCK PLAN(S).

AREA INCLUDES A/C LEDGE, BALCONY AND JULIET BALCONY WHERE APPLICABLE. THE ABOVE PLANS AND ILLUSTRATIONS ARE SUBJECT TO CHANGE AS MAY BE REQUIRED OR APPROVED BY THE RELEVANT AUTHORITIES. ALL FLOOR AREAS ARE APPROXIMATE ONLY AND SUBJECT TO FINAL SURVEY. PLEASE REFER TO KEY PLAN FOR ORIENTATION.

BP No.: A2788-03660-2020-BP01 dated 05-06-2023

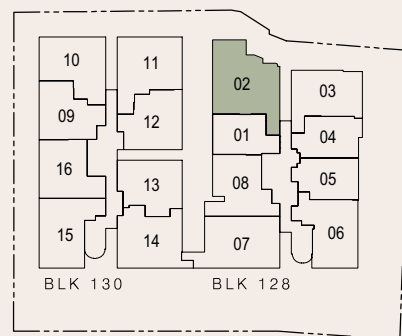

KEY PLAN
 NOT DRAWN TO SCALE

BALCONY SCREEN DETAILS

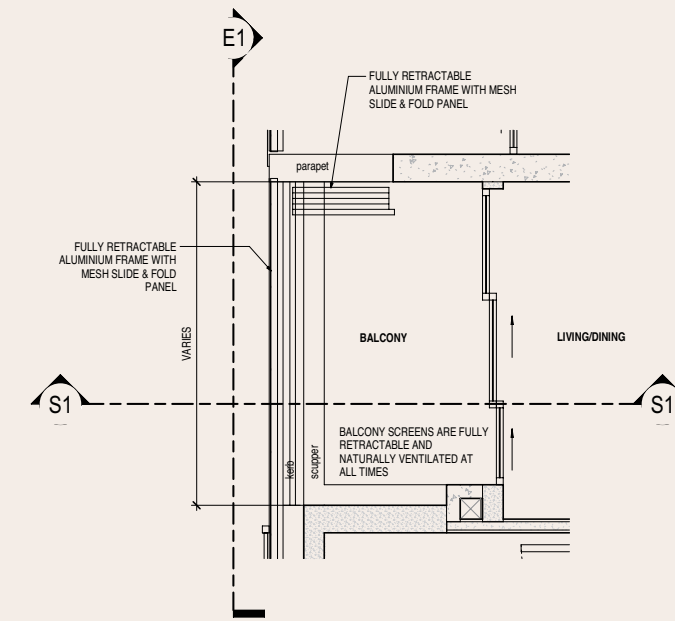

TYPICAL RETRACTABLE BALCONY SCREEN PLANS

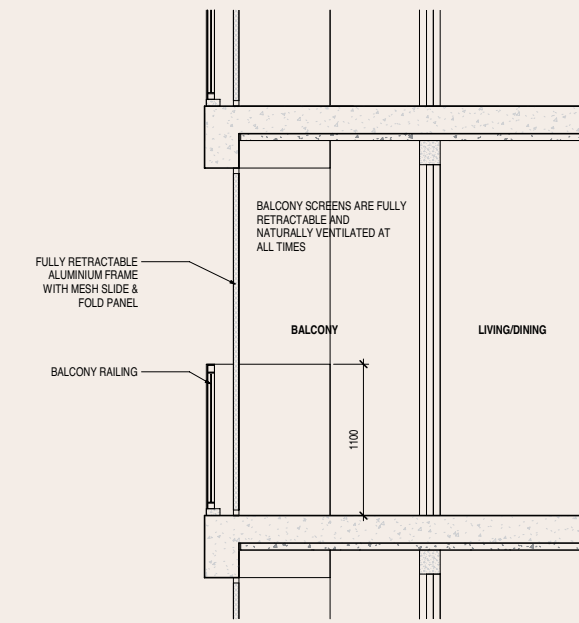

TYPICAL RETRACTABLE BALCONY SCREEN SECTION

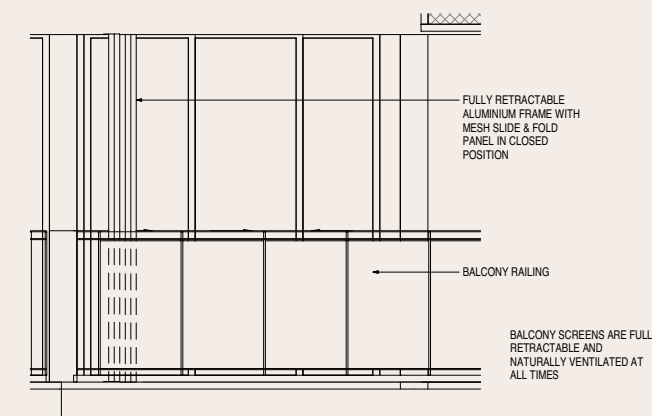

TYPICAL RETRACTABLE BALCONY SCREEN ELEVATION (OPEN)

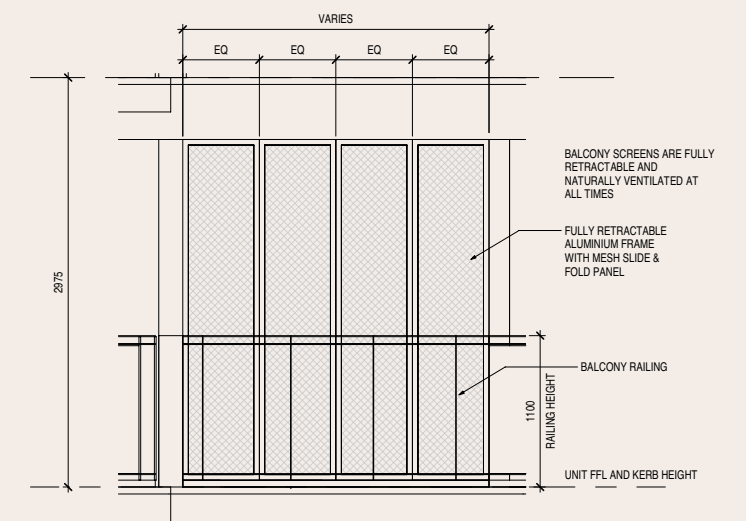

TYPICAL RETRACTABLE BALCONY SCREEN ELEVATION (CLOSED)